



**Your best bet
for everything
under the *cherry*,
in the **FROSTED** glass
and above the **CONE**
since 1929.**

Product Catalog



Yesterday

Founded in 1929, SaniServ® began as a manufacturer of amusement park equipment in Indianapolis, Indiana. In 1931, the company manufactured the very first frozen custard machine.

In 1951, a continuous type ice cream freezer called a “SaniServ” was introduced, and in 1955 a continuous milk shake dispensing machine became part of the product offering. A year later, an automatic hamburger flame broiler was introduced which formed the basis for the Burger Chef fast food chain headquartered in Indianapolis

During the mid 60’s, SaniServ manufactured 80% of all equipment used in Burger Chef’s restaurants. Hardee’s purchased Burger Chef from General Foods in 1980 and converted all units to the Hardee’s brand. SaniServ continued to grow and prosper with their core products of ice cream and frozen beverage machines.

Today and Tomorrow

SaniServ® was purchased by current management in 1998. New management brought a broad range of knowledge and experience in manufacturing, research and development, sales and marketing, and national accounts.

SaniServ® acquired Southern Equipment Company’s “Seco” division of racks, cabinets, tables and equipment stands in 1999. Manufacturing operations were moved into the SaniServ® facility at that time. The Seco products, reintroduced by SaniServ®, are known for their quality and institutional service reliability. SaniServ acquired a small wares manufacturer of plastic containers and accessories in 2006.

SaniServ® sells to every customer base in the food-service industry including consultant-specified bid and institutional work, government and the military and private business through designated distributors and foodservice equipment representatives.

Chains are an important and growing part of SaniServ’s business. SaniServ® currently has product approvals for many top chains, including: Burger King, Wendy’s, Fazoli’s, Outback, Applebee’s, Don Pablo’s, Lone Star, Red Robin, Krystal’s, Texas Roadhouse, White Castle and many more.

SaniServ offers a unique blend of value, quality, flexibility, expertise and customer service to meet and exceed our customer’s expectations.

Soft Serv / YOGURT FREEZERS

Model 407.....	4
Model 408.....	6
Model 401	8
Model 404	10
Model 414	12
Model 424	14
Model 501 <i>Twist</i>	16
Model 527 <i>Twist</i>	18
Model 521 <i>Twist</i>	20
Model 522 <i>Twist</i>	22



SHAKE FREEZERS

Model 608.....	24
Model 601.....	26
Model 614	28
Model 624	30
Model 601SAS	32
Model 614SAS	34
Model 691.....	36
Model 824 <i>Shake & Soft Serv</i>	38
Model 808.....	40



Table of Contents

FROZEN BEVERAGE DISPENSERS

Model 707.....	42
Model 708.....	44
Model 108.....	46
Model 709.....	48
Model 704.....	50
Model 791.....	52
Model 798 <i>Twin</i>	54
Model 714.....	56
Model 724 <i>Twin</i>	58
Model 701SAS.....	60
Model 714SAS.....	62
Model 708PBS <i>Pressurized</i>	64



REMOTE BEVERAGE DISPENSERS

Model 108R <i>Remote</i>	66
Model 798R <i>Twin Remote</i>	68
Model WB700 <i>Remote</i>	70
Model WB700-2 <i>Remote</i>	72
Model WB7110 <i>Remote</i>	74

DURAFREEZE ECONOMY SERIES

DF100 Frozen Beverage.....	76
DF200 Soft Serv Freezer.....	78
DF300 Batch Freezer.....	80



BATCH FREEZERS

B-5 Batch Freezer.....	82
B-10 Batch Freezer.....	84
B-20 Batch Freezer.....	86

CYCLONE Mixer.....	88
--------------------	----

AUTO FILL SYSTEM

SASF12.....	90
SASF24.....	90

STAINLESS STEEL

EQUIPMENT STANDS.....	92
Remote Condensing Unit.....	93

ACCESSORIES

Bucket Hanger.....	94
Insulated Lid.....	95
Storage Containers.....	96
Cord Set.....	97
Auto Fill Kit.....	98
Light Box.....	98
Parts Tray.....	98
Wash Out Kit.....	98
Drink Spinner.....	99
Syrup Rails & Dispensers.....	99





DESIGNED FOR LOWER VOLUME APPLICATIONS

Two - 4 oz. Servings per Minute - 7 Qt. Capacity

GREAT FOR CAFES, RESTAURANTS, AND PRODUCT SAMPLING

The **SaniServ** model 407 Soft Serv Freezer is perfect for providing small servings, samplers, and adding a-la-mode to favorite desserts. The 407 is an economical addition to any restaurant with its affordable price and space saving countertop solution. The 407 is always a favorite among operators to supply a limited amount of Soft Serv ice cream and frozen yogurt products to keep customers coming back for more treats!

SPACE SAVING

Small Footprint Design - SaniServ model 407 saves valuable floor space and turns the countertop into a real profit center by serving high profit ice cream and yogurt products.

EASY CLEANING AND OPERATION

Fewer Parts = Simplified Cleaning - SaniServ equipment is designed and built with the fewer parts to be disassembled, cleaned and sanitized than any other machine in the industry.

HIGH RETURN ON INVESTMENT

Increased Profits - SaniServ machines combine efficiency with consistent product quality and fast quiet operation while insuring customer satisfaction with high profit ice cream or yogurt products.

QUALITY DESIGN

Durability - SaniServ machines are built to achieve long and dependable life through simplicity of design. Every machine is shipped standard with a stainless steel exterior, durable steel interior frame construction, heavy-duty components and consistency systems.

Model 407

Countertop
Soft Serv
Ice Cream / Yogurt Machine



Made in USA

We reserve the right to change specifications and products design without notice. Such revisions do not entitle the buyer to corresponding changes, improvements, additions or replacements for previously purchased equipment

MODEL 407

Counter Model Soft Serv / Yogurt Freezer

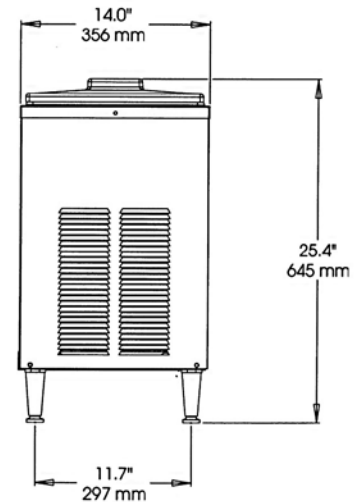
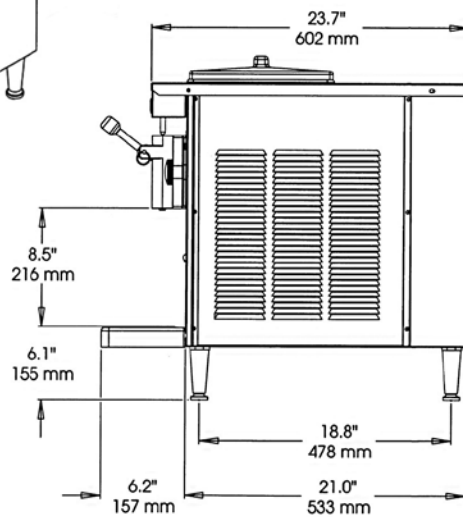
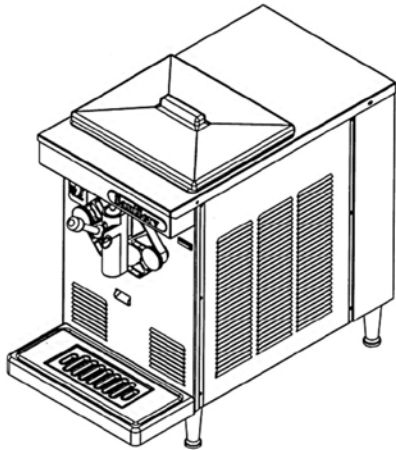

Minimum Wall Clearance
Both Sides and Back -
6 inches (152 mm)

ELECTRICAL				WIDTH	HEIGHT	DEPTH	WEIGHT	VOLUME
VOLTS	Hz	Ph.	Amps	INCHES (MM)	INCHES (MM)	INCHES (MM)	LBS. (Kg)	CU FT. (cu. m.)
115	60	1	15	14 (356)	25.4 (645)	23.7 (602)	145 (66)	
208-230	60	1	10					
220-240	50	1	10					
Shipping Specifications				22.5 (571)	31.5 (800)	34.5 (876)	172 (78)	8.6 (.25)

Specifications:

Cooling System:
Air Only

Dasher and Compressor Motors:
1/2 HP Dasher
1/2 HP Compressor

Refrigerant Type:
R404A

Listings:
UL, cUL, NSF

Features:

Evaporator and Mix Reservoir Capacity:
7 Quarts (9.5 liters)

Dasher:
Heavy-Duty Stainless Steel with low friction scraper blades.

Controls:
Automatically consistency controls for improved consistency.

Tamper Proof Automatic Visual Mix Out System

Warranty:

Parts 1 year
Compressor 5 years
Evaporator 5 years

Options:

Tune Up Kit
Machine Stand
Export Voltages



DESIGNED FOR LOW-MEDIUM VOLUME APPLICATIONS

Four – 4 oz. Servings per Minute – 20 Qt. Capacity

GREAT FOR SMALLER RESTAURANTS AND KITCHENS

The **SaniServ** model 408 Soft Serv Freezer allows business owners to affordably provide high profit Soft Serv and frozen yogurt products with the convenience of 115-volt electrical access. The 408 can handle producing product for all day operations and is a favorite among owners in satisfying customer demand for great frozen treats any time; any place!

SPACE SAVING

Small Footprint Design - SaniServ model 408 with its compact design and production versatility saves valuable floor space and turns the countertop into a real profit center by adding and serving high profit ice cream and yogurt products.

EASY CLEANING AND OPERATION

Fewer Parts = Simplified Cleaning – SaniServ equipment is designed and built with the fewer parts to be disassembled, cleaned and sanitized than any other machine in the industry.

HIGH RETURN ON INVESTMENT

Increased Profits – SaniServ machines combine efficiency with consistent product quality and fast quiet operation while insuring customer satisfaction with high profit ice cream or yogurt products.

QUALITY DESIGN

Durability – SaniServ machines are built to achieve long and dependable life through simplicity of design. Every machine is shipped standard with a stainless steel exterior, durable steel interior frame construction, heavy-duty components and consistency systems.

Model 408

Countertop
Soft Serv
Ice Cream / Yogurt Machine



Made in USA

We reserve the right to change specifications and products design without notice. Such revisions do not entitle the buyer to corresponding changes, improvements, additions or replacements for previously purchased equipment



MODEL 408

Counter Model Soft Serv / Yogurt Freezer

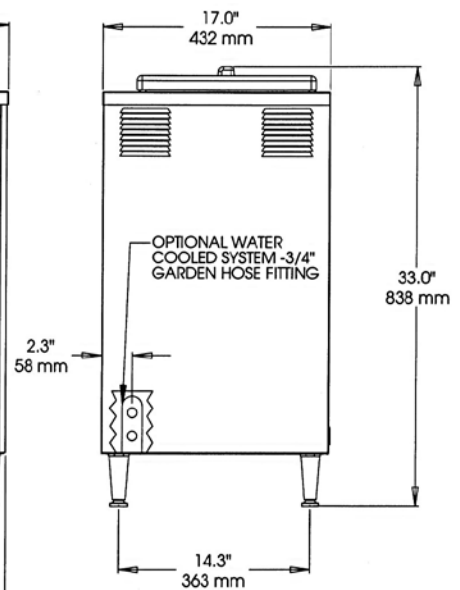
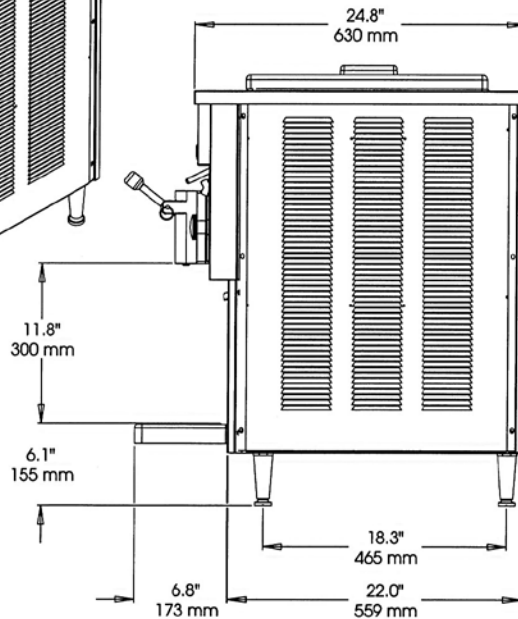
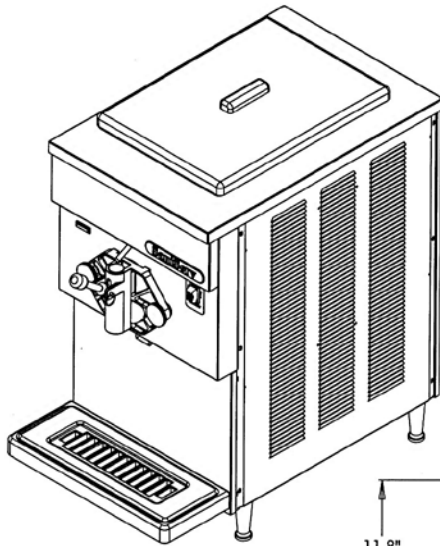

Minimum Wall Clearance
Both Sides and Back -
6 inches (152 mm)

ELECTRICAL				WIDTH	HEIGHT	DEPTH	WEIGHT	VOLUME
VOLTS	Hz	Ph.	Amps	INCHES (MM)	INCHES (MM)	INCHES (MM)	LBS. (Kg)	CU FT. (cu. m.)
115	60	1	30	17 (432)	33.0 (838)	24.8 (630)	230 (105)	
Shipping Specifications				22.5 (572)	41 (1042)	34.5 (876)	260 (118)	18.5 (.53)

Specifications:

Cooling System:

Air or Water

Dasher and Compressor Motors:

1 HP Dasher
3/4 HP Compressor

Refrigerant Type:

R404A

Listings:

UL, cUL, NSF

Features:

Evaporator and Mix Reservoir

Capacity:
20 Quarts (18.9 liters)

Dasher:

Heavy-Duty Stainless Steel with low friction scraper blades.

Controls:

Automatically consistency controls for improved consistency.

Tamper Proof Automatic Visual Mix Out System

Warranty:

Parts 1 year
Compressor 5 years
Evaporator 5 years

Options:

Tune Up Kit
Parts Tray
Syrup Rail
Counter Top Mounting Pad Machine Stand
Water Cooled - 3/4" Garden Hose Fitting
Wash Out Kit - 3/8" Flare Fitting



DESIGNED FOR MEDIUM VOLUME APPLICATIONS

Five – 4 oz. Servings per Minute – 20 Qt. Capacity

GREAT FOR RESTAURANTS AND CONCESSIONAIRES

The **SaniServ** model 401 Soft Serv Freezer provides high profit, consistent quality Soft Serv and yogurt products anytime anywhere! Fewer parts to clean and sanitize means rapid disassembly and assembly and the ease of operation makes the 401 a favorite among owners and operators. The increased production, capacity and recovery time make the 401 a perfect piece of equipment for satisfying customer demand and providing the frozen treats they want!

SPACE SAVING

Small Footprint Design - SaniServ model 401 saves valuable floor space and turns the countertop into a real profit center by serving high profit ice cream and yogurt products.

EASY CLEANING AND OPERATION

Fewer Parts = Simplified Cleaning – SaniServ equipment is designed and built with the fewer parts to be disassembled, cleaned and sanitized than any other machine in the industry. The state of the art solid-state **AccuFreeze** control insures product consistency, worry-free operation and customer satisfaction.

HIGH RETURN ON INVESTMENT

Increased Profits – SaniServ machines combine efficiency with consistent product quality and fast quiet operation while insuring customer satisfaction with high profit ice cream or yogurt products.

QUALITY DESIGN

Durability – SaniServ machines are built to achieve long and dependable life through simplicity of design. Every machine is shipped standard with a stainless steel exterior, durable steel interior frame construction, heavy-duty components and consistency systems.

Model 401

Countertop
Soft Serv
Ice Cream / Yogurt Machine
With **AccuFreeze** Control



Made in USA

We reserve the right to change specifications and products design without notice. Such revisions do not entitle the buyer to corresponding changes, improvements, additions or replacements for previously purchased equipment

MODEL 401

Counter Model Soft Serv / Yogurt Freezer

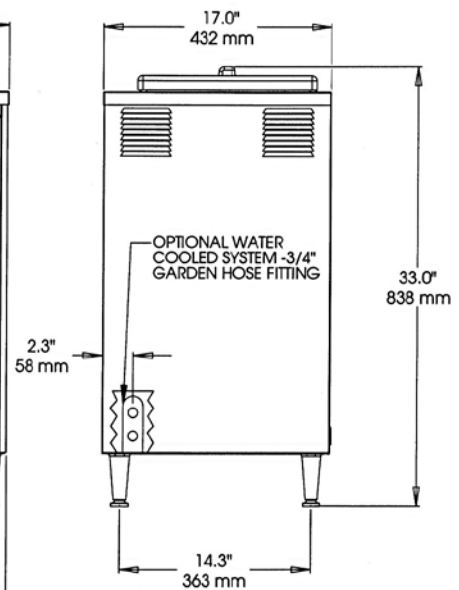
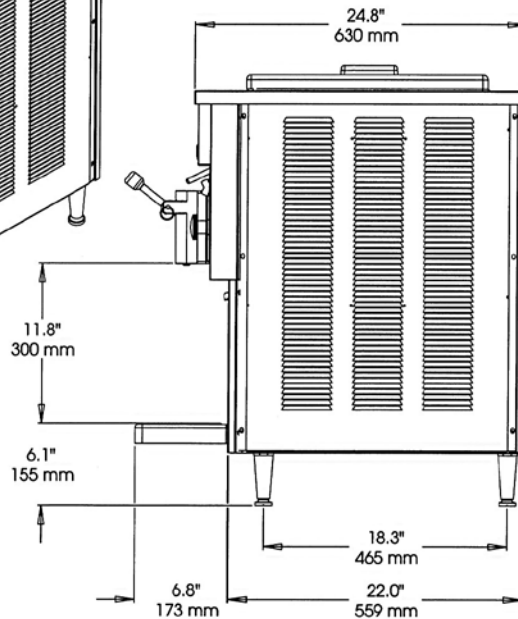
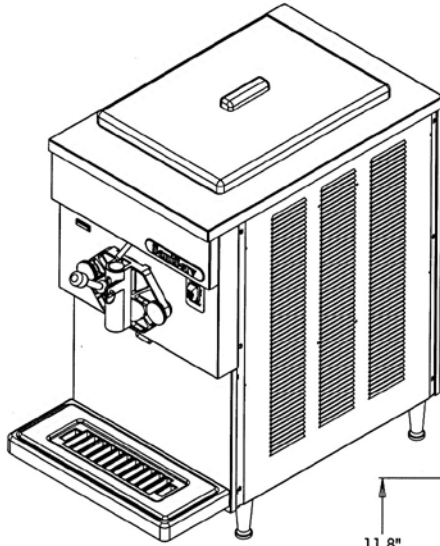

Minimum Wall Clearance
Both Sides and Back -
6 inches (152 mm)

ELECTRICAL				WIDTH	HEIGHT	DEPTH	WEIGHT	VOLUME
VOLTS	Hz	Ph.	Amps	INCHES (MM)	INCHES (MM)	INCHES (MM)	LBS. (Kg)	CU FT. (cu. m.)
208-230	60	1	20	17 (432)	33.0 (838)	24.8 (630)	242 (110)	
208-230	60	3	15					
Shipping Specifications				22.5 (572)	41 (1042)	34.5 (876)	272 (124)	18.5 (.53)

Specifications:

Cooling System:
Air or Water

Dasher and Compressor Motors:
1 HP Dasher
1 HP Compressor

Refrigerant Type:
R404A

Listings:
UL, cUL, NSF

Features:

Evaporator and Mix Reservoir Capacity:
20 Quarts (18.9 liters)

Dasher:
Heavy-Duty Stainless Steel with low friction scraper blades.

Controls:
AccuFreeze solid-state control for accurate product consistency.

Solid State Audio/Visual Mix Out System with Compressor Lockout

Warranty:

Parts 1 year
Compressor 5 years
Evaporator 5 years

Options:

Tune Up Kit
Parts Tray
Syrup Rail
Counter Top Mounting Pad Machine Stand
Water Cooled - 3/4" Garden Hose Fitting
Wash Out Kit - 3/8" Flare Fitting



DESIGNED FOR HIGHER VOLUME APPLICATIONS

Seven – 4 oz. Servings per Minute – 20 Qt. Capacity

GREAT FOR RESTAURANTS, BUFFETS, & ICE CREAM SHOPS

The **SaniServ** model 404 Soft Serv Freezer provides the highest volume of frozen product in a countertop design in the SaniServ product lineup. The high production and quick recovery time of the 404 insures customers are always supplied with their favorite frozen treats and the ease of operation always makes the 404 a favorite among high volume owners and operators!

SPACE SAVING

Small Footprint Design - **SaniServ** model 404 saves valuable floor space and turns the countertop into a real profit enter by serving a high volume of high profit ice cream and yogurt products.

EASY CLEANING AND OPERATION

Fewer Parts = Simplified Cleaning – **SaniServ** equipment is designed and built with the fewer parts to be disassembled, cleaned and sanitized than any other machine in the industry. The state of the art solid-state **AccuFreeze** control insures product consistency, worry-free operation and customer satisfaction.

HIGH RETURN ON INVESTMENT

Increased Profits – **SaniServ** machines combine efficiency with consistent product quality and fast quiet operation while insuring customer satisfaction with high profit ice cream or yogurt products.

QUALITY DESIGN

Durability – **SaniServ** machines are built to achieve long and dependable life through simplicity of design. Every machine is shipped standard with a stainless steel exterior, durable steel interior frame construction, heavy-duty components and consistency systems.

Model 404

Countertop
Soft Serv
Ice Cream / Yogurt Machine
With **AccuFreeze** Control



Made in USA

We reserve the right to change specifications and products design without notice. Such revisions do not entitle the buyer to corresponding changes, improvements, additions or replacements for previously purchased equipment



MODEL 404

Counter Model Soft Serv / Yogurt Freezer

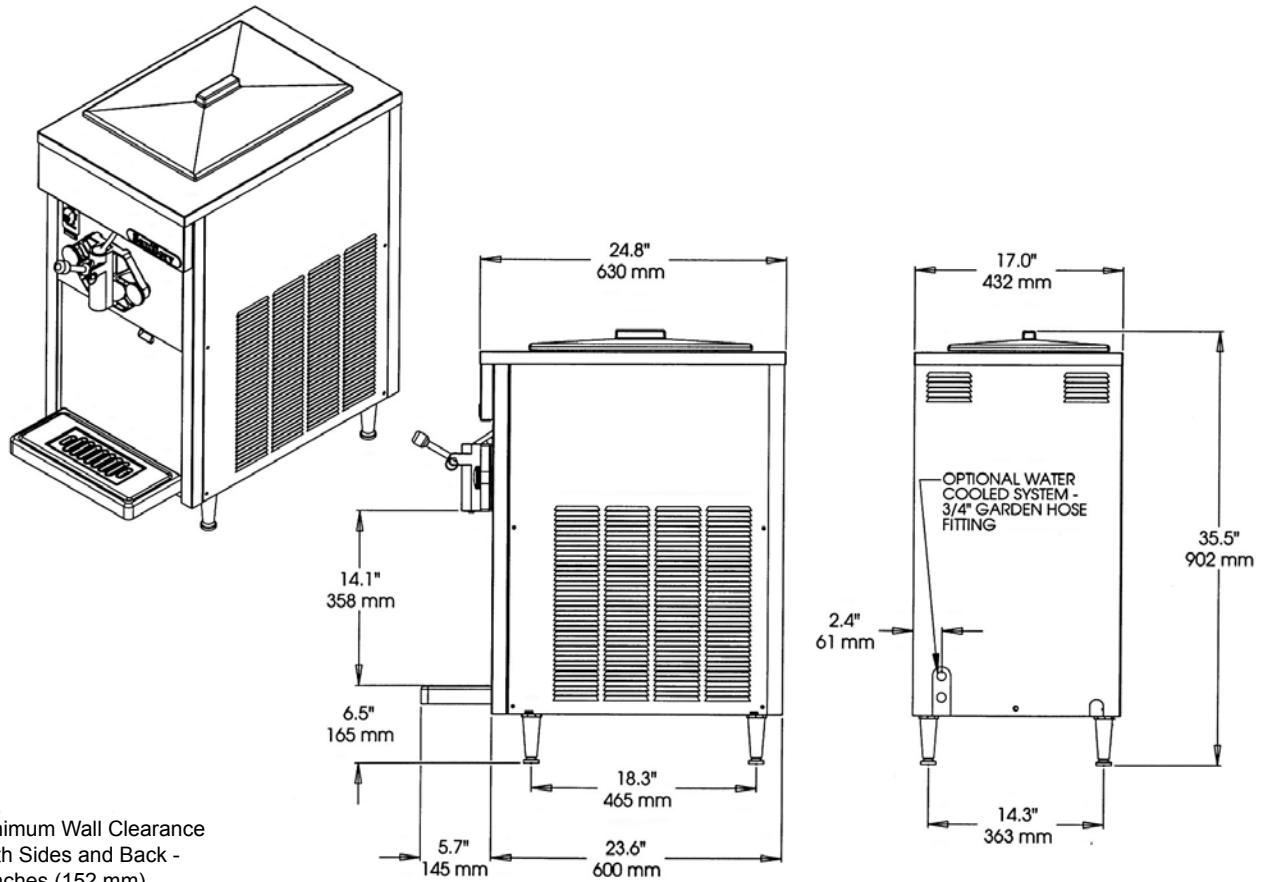

Minimum Wall Clearance
Both Sides and Back -
6 inches (152 mm)

ELECTRICAL				WIDTH	HEIGHT	DEPTH	WEIGHT	VOLUME
VOLTS	Hz	Ph.	Amps	INCHES (MM)	INCHES (MM)	INCHES (MM)	LBS. (Kg)	CU FT. (cu. m.)
208-230	60	1	30	17 (432)	35.5 (902)	24.8 (630)	250 (113)	
208-230	60	3	20					
Shipping Specifications				22.5 (572)	41 (1042)	34.5 (876)	268 (122)	18.5 (.53)

Specifications:

Cooling System:

Air or Water

Dasher and Compressor Motors:

1 HP Dasher
2 HP Compressor

Refrigerant Type:

R404A

Listings:

UL, cUL, NSF

Features:

Evaporator and Mix Reservoir

Capacity:
20 Quarts (18.9 liters)

Dasher:

Heavy-Duty Stainless Steel with low friction scraper blades.

Controls:

AccuFreeze solid-state control for accurate product consistency.

Tamper Proof Visual Mix Out System With Compressor Lockout

Warranty:

Parts 1 year
Compressor 5 years
Evaporator 5 years

Options:

Tune Up Kit
Parts Tray
Syrup Rail
Counter Top Mounting Pad Machine Stand
Water Cooled - 3/4" Garden Hose Fitting
Wash Out Kit - 3/8" Flare Fitting



DESIGNED FOR HIGHER VOLUME APPLICATIONS

Seven – 4 oz. Servings per Minute – 20 Qt. Capacity

GREAT FOR RESTAURANTS, BUFFETS, & ICE CREAM SHOPS

The **SaniServ** model 414 Soft Serv Freezer provides high profit, consistent quality Soft Serv and yogurt products in a traditional single barrel design! The ease of operation of the model 414 is a favorite among owners and operators. The high production, capacity and recovery time insures the 414 is a perfect piece of equipment for satisfying customer demand and providing the frozen treats they want at any time!

SPACE SAVING

Compact Floor Model Design - SaniServ model 414 provides a high volume of Soft Serv and frozen yogurt products in the traditional floor model design. Operators can turn that valuable floor space into a high profit center by providing frozen treats customers enjoy!

EASY CLEANING AND OPERATION

Fewer Parts = Simplified Cleaning – SaniServ equipment is designed and built with the fewer parts to be disassembled, cleaned and sanitized than any other machine in the industry. The state of the art solid-state **AccuFreeze** control insures product consistency, worry-free operation and customer satisfaction.

HIGH RETURN ON INVESTMENT

Increased Profits – SaniServ machines combine efficiency with consistent product quality and fast quiet operation while insuring customer satisfaction with high profit ice cream or yogurt products.

QUALITY DESIGN

Durability – SaniServ machines are built to achieve long and dependable life through simplicity of design. Every machine is shipped standard with a stainless steel exterior, durable steel interior frame construction, heavy-duty components and consistency systems.

Model 414

Floor Model
Soft Serv
Ice Cream / Yogurt Machine
With **AccuFreeze** Control



Made in USA

We reserve the right to change specifications and products design without notice. Such revisions do not entitle the buyer to corresponding changes, improvements, additions or replacements for previously purchased equipment

MODEL 414

Floor Model Shake Freezer

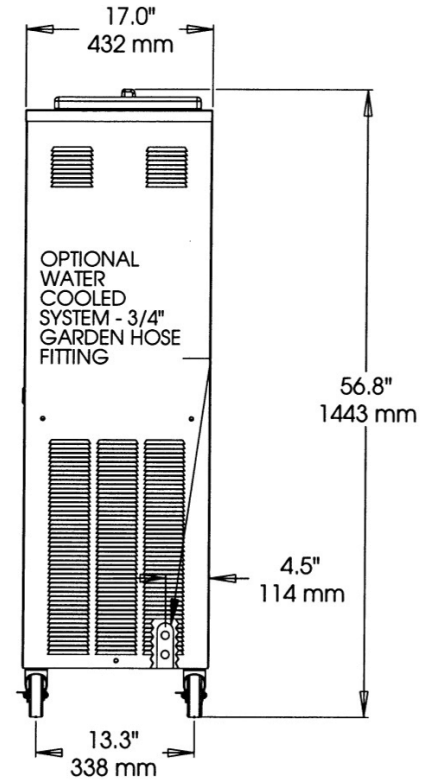
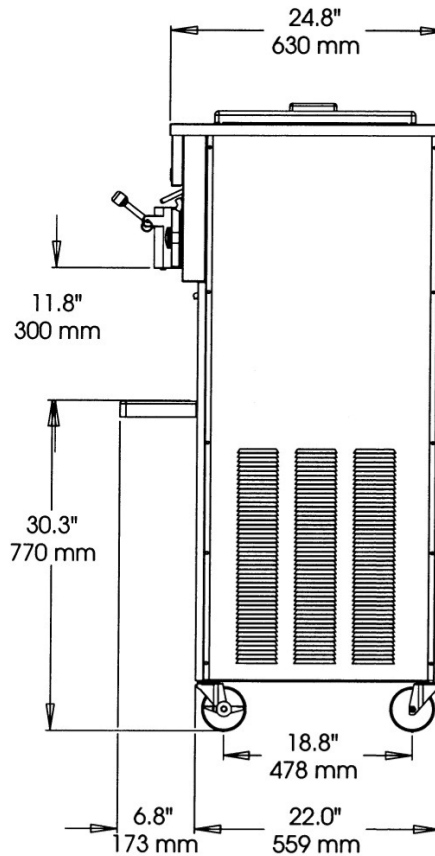
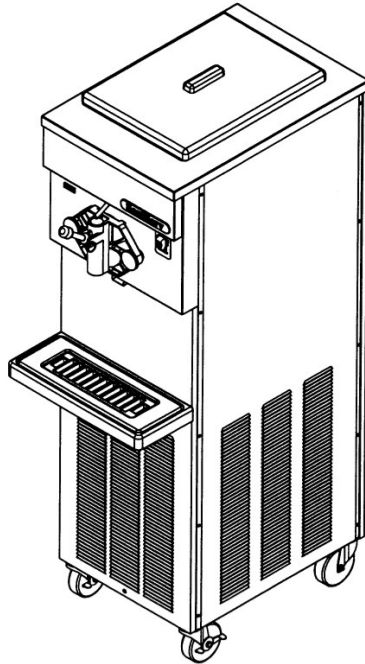

Minimum Wall Clearance
Both Sides and Back -
6 inches (152 mm)

ELECTRICAL				WIDTH	HEIGHT	DEPTH	WEIGHT	VOLUME
VOLTS	Hz	Ph.	Amps	INCHES (MM)	INCHES (MM)	INCHES (MM)	LBS. (Kg)	CU FT. (cu. m.)
208-230	60	1	30	17 (432)	56.5 (1435)	24.8 (630)	338 (153)	
208-230	60	3	20					
Shipping Specifications				24.5 (622)	58.1 (1476)	40.5 (1029)	380 (172)	32.4 (.92)

Specifications:

Cooling System:
Air or Water

Dasher and Compressor Motors:
1 HP Dasher
2 HP Compressor

Refrigerant Type:
R404A

Listings:
UL, cUL, NSF

Features:

Evaporator and Mix Reservoir Capacity:
20 Quarts (18.9 liters)

Dasher:
Heavy-Duty Stainless Steel with low friction scraper blades.

Controls:
AccuFreeze solid-state control for accurate product consistency.

Solid State Audio/Visual Mix Out System with Compressor Lockout

Warranty:

Parts 1 year
Compressor 5 years
Evaporator 5 years

Options:

Tune Up Kit
Parts Tray
Syrup Rail
Water Cooled - 3/4" Garden Hose Fitting
Wash Out Kit - 3/8" Flare Fitting



DESIGNED FOR HIGHER VOLUME APPLICATIONS

Seven – 4 oz. Servings per Minute per side and 20 Qt. Capacity per side

GREAT FOR RESTAURANTS, BUFFETS, & ICE CREAM SHOPS

The **SaniServ** model 424 Twin Flavor Soft Serv Freezer can provide not one but two favorite high profit, consistent quality Soft Serv and yogurt products in a dual barrel design! The ease of the model 424's operation and product versatility is a favorite among owners and operators. The high production, capacity and recovery time insures the 424 is a perfect piece of equipment for satisfying enough of any two customer favorite frozen treats at any time!

HEAVY DUTY

Traditional Floor Model Design - SaniServ model 424 provides a high volume of two flavors of Soft Serv and frozen yogurt products in the traditional floor model design. Operators can turn that valuable floor space into a high profit center by providing two frozen favorite treats customers enjoy!

EASY CLEANING AND OPERATION

Fewer Parts = Simplified Cleaning – SaniServ equipment is designed and built with the fewer parts to be disassembled, cleaned and sanitized than any other machine in the industry. The state of the art solid-state **AccuFreeze** control insures product consistency, worry free operation and customer satisfaction.

HIGH RETURN ON INVESTMENT

Increased Profits – SaniServ machines combine efficiency with consistent product quality and fast quiet operation while insuring customer satisfaction with high profit ice cream or yogurt products.

QUALITY DESIGN

Durability – SaniServ machines are built to achieve long and dependable life through simplicity of design. Every machine is shipped standard with a stainless steel exterior, durable steel interior frame construction, heavy-duty components and consistency systems.

Model 424

Floor Model
Twin Soft Serv
Ice Cream / Yogurt Machine
With **AccuFreeze** Control



Made in USA

We reserve the right to change specifications and products design without notice. Such revisions do not entitle the buyer to corresponding changes, improvements, additions or replacements for previously purchased equipment



MODEL 424

Floor Model *Twin Soft Serv / Yogurt Freezer*

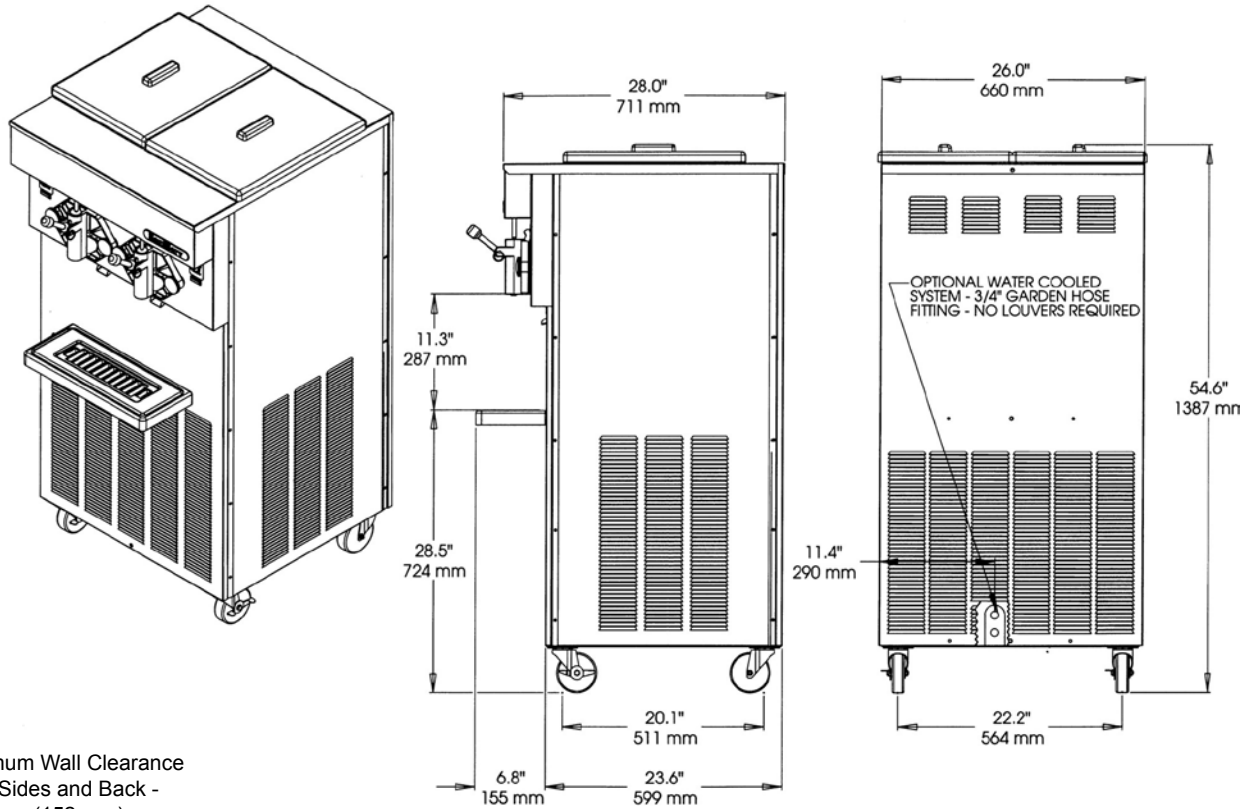

Minimum Wall Clearance
Both Sides and Back -
6 inches (152 mm)

ELECTRICAL				WIDTH	HEIGHT	DEPTH	WEIGHT	VOLUME
VOLTS	Hz	Ph.	Amps	INCHES (MM)	INCHES (MM)	INCHES (MM)	LBS. (Kg)	CU FT. (cu. m.)
208-230	60	1	2x30	26 (660)	54.6 (1387)	28 (711)	575 (261)	
208-230	60	3	2x20					
Shipping Specifications				37 (940)	60 (1524)	41 (1024)	615 (279)	52.7 (1.49)

Specifications:

Cooling System:
Air or Water

Dasher and Compressor Motors:
(2) 1 HP Dasher
(2) 2 HP Compressor

Refrigerant Type:
R404A

Features:

Evaporator and Mix Reservoir Capacity:
20 Quarts (18.9 liters)

Dasher:
Heavy-Duty Stainless Steel with low friction scraper blades.

Controls:
AccuFreeze solid-state control for accurate product consistency.

Solid State Audio/Visual Mix Out System with Compressor Lockout

Warranty:

Parts 1 year
Compressor 5 years
Evaporator 5 years

Options:

Tune Up Kit
Parts Tray
Syrup Rail
Water Cooled - 3/4" Garden Hose Fitting
Wash Out Kit - 3/8" Flare Fitting
Export Voltages



DESIGNED FOR MEDIUM VOLUME APPLICATIONS

Four – 4 oz. Servings per Minute per side and 11 Qt. Capacity per side

IDEAL FOR RESTAURANTS, CONCESSIONAIRES AND AMUSEMENT PARKS

The **SaniServ** model 501 Soft Serv Freezer is a favorite in providing versatility to serve two individual flavors as well as a flavor twist. The 501 offers high profit, consistent quality Soft Serv and yogurt products in a popular countertop design. Two independent flavor hoppers and barrels guarantee separation of product and flavors. Ease of operation insures the 501 as a favorite among owners and operators while providing customers the popular flavor twist they enjoy!

SPACE SAVING

Small Footprint Design - SaniServ model 501 saves valuable floor space and turns the countertop into a real profit center by serving two high profit ice cream and yogurt product flavors along with the ability to twist the flavors into a frozen favorite.

EASY CLEANING AND OPERATION

Fewer Parts = Simplified Cleaning – SaniServ equipment is designed and built with the fewer parts to be disassembled, cleaned and sanitized than any other machine in the industry. The state of the art solid-state **AccuFreeze** control insures product consistency, worry free operation and customer satisfaction.

HIGH RETURN ON INVESTMENT

Increased Profits – SaniServ machines combine efficiency with consistent product quality and fast quiet operation while insuring customer satisfaction with high profit ice cream or yogurt products.

QUALITY DESIGN

Durability – SaniServ machines are built to achieve long and dependable life through simplicity of design. Every machine is shipped standard with a stainless steel exterior, durable steel interior frame construction, heavy-duty components and consistency systems.

Model 501

Countertop
Twist Soft Serv
Ice Cream / Yogurt Machine
With **AccuFreeze** Control



Made in USA

We reserve the right to change specifications and products design without notice. Such revisions do not entitle the buyer to corresponding changes, improvements, additions or replacements for previously purchased equipment



MODEL 501

Counter Model *Twist Soft Serv / Yogurt Freezer*

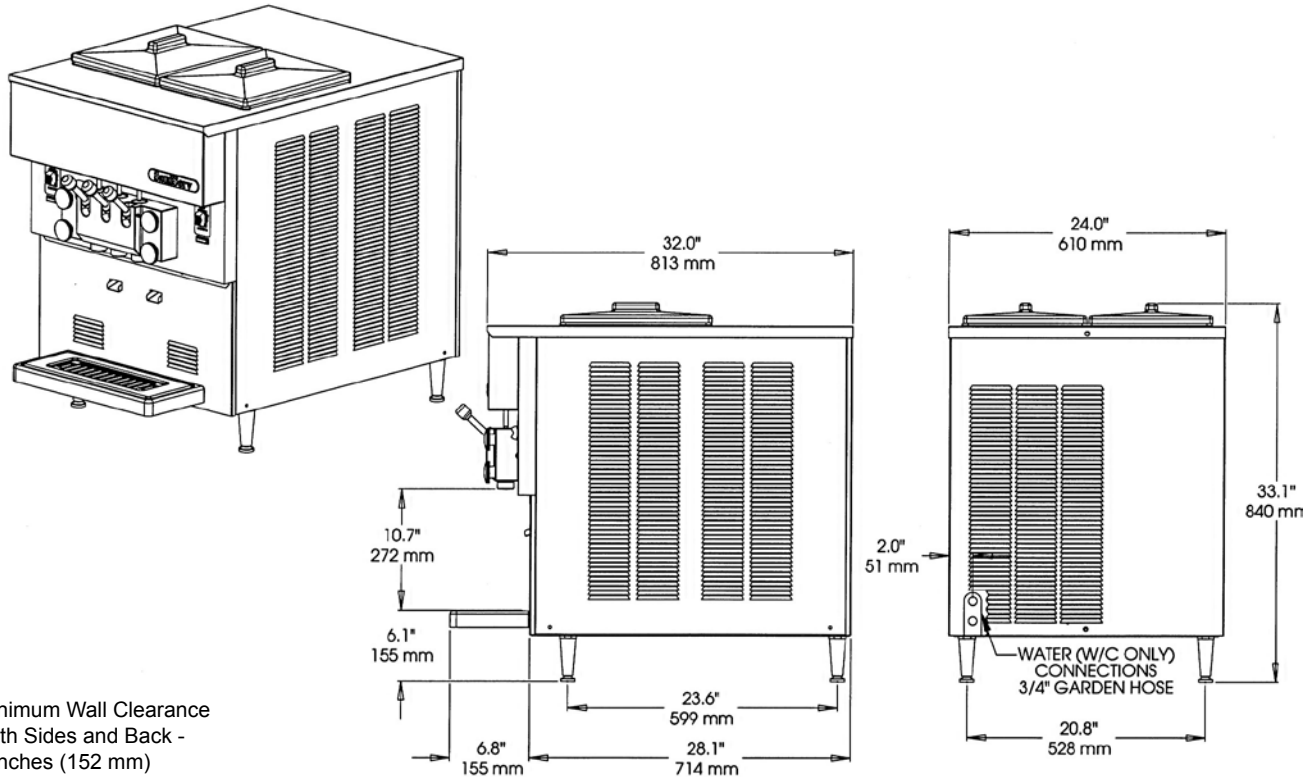

Minimum Wall Clearance
Both Sides and Back -
6 inches (152 mm)

ELECTRICAL				WIDTH	HEIGHT	DEPTH	WEIGHT	VOLUME
VOLTS	Hz	Ph.	Amps	INCHES (MM)	INCHES (MM)	INCHES (MM)	LBS. (Kg)	CU FT. (cu. m.)
208-230	60	1	30	24 (610)	33.1 (826)	32 (813)	400 (182)	
208-230	60	3	25					
Shipping Specifications				31.5 (800)	40.5 (1029)	40.5 (1029)	435 (198)	28.4 (.79)

Specifications:

Cooling System:
Air or Water

Dasher and Compressor Motors:
(2) 1 HP Dashers
(1) 2 HP Compressor

Refrigerant Type:
R404A

Listings:
UL, cUL, NSF

Features:

Evaporator and Mix Reservoir Capacity:
11 Quarts (10.4 liters) per side

Dasher:
Heavy-Duty Stainless Steel with low friction scraper blades.

Controls:
AccuFreeze solid-state control for accurate product consistency.

Solid State Audio/Visual Mix Out System with Compressor Lockout

Warranty:

Parts 1 year
Compressor 5 years
Evaporator 5 years

Options:

Tune Up Kit
Parts Tray
Syrup Rail
Counter Top Mounting Pad Machine Stand
Water Cooled - 3/4" Garden Hose Fitting
Wash Out Kit - 3/8" Flare Fitting



DESIGNED FOR MEDIUM VOLUME APPLICATIONS

Four – 4 oz. Servings per Minute per side and 11 Qt. Capacity per side

IDEAL FOR SELF-SERVICE OPERATIONS, SCHOOLS & RESTAURANTS

The **SaniServ** model 527 Soft Serv Freezer is a favorite in providing versatility to serve two individual flavors as well as a flavor twist. The 527 offers high profit, consistent quality Soft Serv and yogurt products in a popular countertop design. Two independent flavor hoppers and barrels guarantee separation of product and flavors. Ease of operation insures the 527 as a favorite among owners and operators while providing customers the popular flavor twist they enjoy!

HEAVY DUTY

Traditional Floor Model Design - SaniServ model 527 turns valuable floor space into a real profit center by serving two high profit ice cream and yogurt product flavors along with the ability to twist the flavors into a frozen favorite.

EASY CLEANING AND OPERATION

Fewer Parts = Simplified Cleaning – SaniServ equipment is designed and built with the fewer parts to be disassembled, cleaned and sanitized than any other machine in the industry. The state of the art solid-state **AccuFreeze** control insures product consistency, worry-free operation and customer satisfaction.

HIGH RETURN ON INVESTMENT

Increased Profits – SaniServ machines combine efficiency with consistent product quality and fast quiet operation while insuring customer satisfaction with high profit ice cream or yogurt products.

QUALITY DESIGN

Durability – SaniServ machines are built to achieve long and dependable life through simplicity of design. Every machine is shipped standard with a stainless steel exterior, durable steel interior frame construction, heavy-duty components and consistency systems.

Model 527

Floor Model
Twist Soft Serv
Ice Cream / Yogurt Machine
With **AccuFreeze** Control



Made in USA

We reserve the right to change specifications and products design without notice. Such revisions do not entitle the buyer to corresponding changes, improvements, additions or replacements for previously purchased equipment



MODEL 527

Floor Model *Twist Soft Serv / Yogurt Freezer*

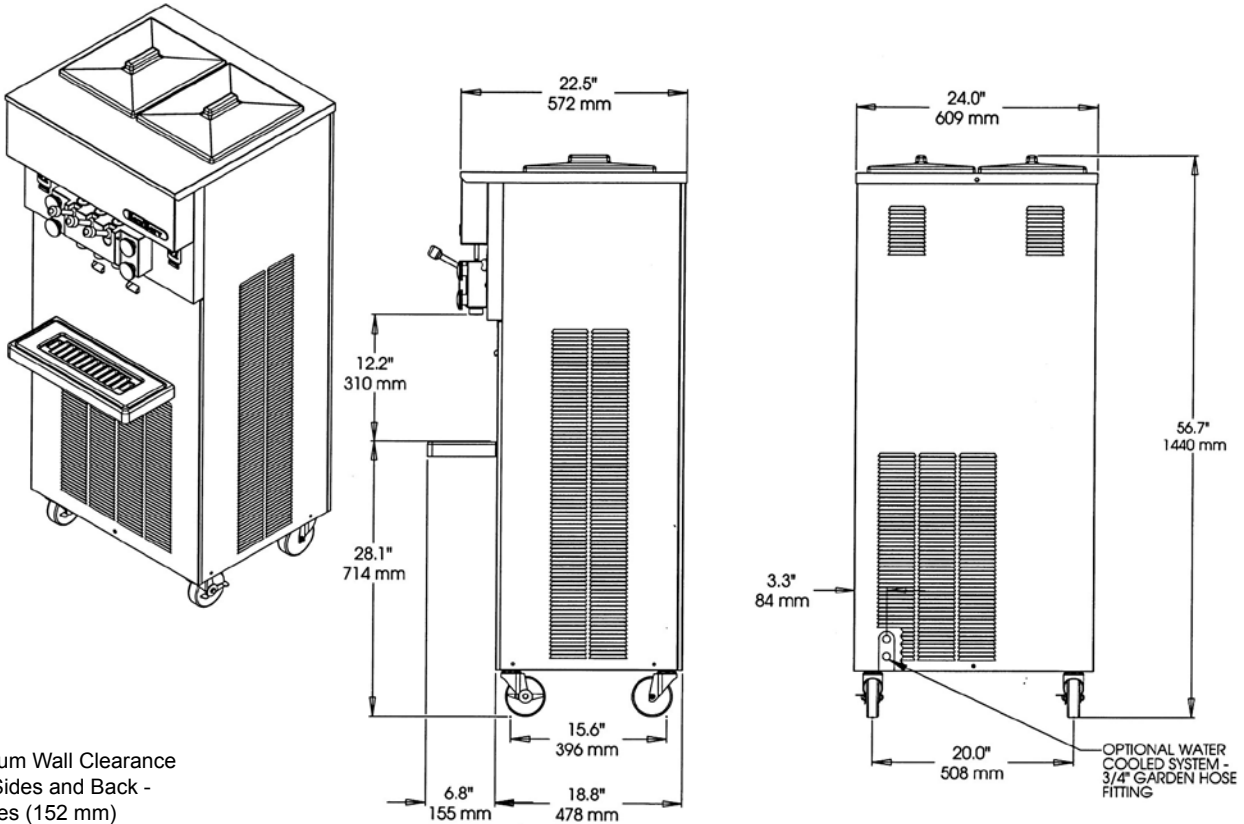

Minimum Wall Clearance
Both Sides and Back -
6 inches (152 mm)

ELECTRICAL				WIDTH	HEIGHT	DEPTH	WEIGHT	VOLUME
VOLTS	Hz	Ph.	Amps	INCHES (MM)	INCHES (MM)	INCHES (MM)	LBS. (Kg)	CU FT. (cu. m.)
208-230	60	1	30	24 (609)	56.7 (1440)	22.5 (572)	448 (204)	
208-230	60	3	25					
Shipping Specifications				37.3 (946)	62 (1575)	41 (1041)	513 (233)	54.8 (1.53)

Specifications:

Cooling System:
Air or Water

Dasher and Compressor Motors:
(2) 1 HP Dashers
(1) 2 HP Compressor

Refrigerant Type:
R404A

Listings:
UL, cUL, NSF

Features:

Evaporator and Mix Reservoir Capacity:
11 Quarts (10.4 liters) per side

Dasher:
Heavy-Duty Stainless Steel with low friction scraper blades.

Controls:
AccuFreeze solid-state control for accurate product consistency.

Solid State Audio/Visual Mix Out System with Compressor Lockout

Warranty:

Parts 1 year
Compressor 5 years
Evaporator 5 years

Options:

Tune Up Kit
Parts Tray
Syrup Rail
Water Cooled - 3/4" Garden Hose Fitting
Wash Out Kit - 3/8" Flare Fitting
Export Voltage



DESIGNED FOR HIGHER VOLUME APPLICATIONS

Five – 4 oz. Servings per Minute per side and 17 Quart Capacity per side

IDEAL FOR SELF-SERV BUFFETS, CAFETERIAS, QUICK SERVICE RESTAURANTS

The **SaniServ** model 521 Soft Serv Freezer provides the highest volume of two individual flavors as well as a flavor twist. The 521 offers the highest volume of high profit, consistent quality Soft Serv and yogurt products in the SaniServ product lineup. Two large independent flavor product reservoirs and barrels guarantee separation of product and flavors. Always easy to operate, large product capacity and quick recovery time insure customers receive their favorite flavors individually or with a twist!

SPACE MAXIMIZING

Traditional Floor Model Design - SaniServ model 521 turns valuable floor space into a real profit center by serving the highest volume of two high profit ice cream and yogurt product flavors along with the ability to twist the flavors into a frozen favorite.

EASY CLEANING AND OPERATION

Fewer Parts = Simplified Cleaning – SaniServ equipment is designed and built with the fewer parts to be disassembled, cleaned and sanitized than any other machine in the industry. The state of the art solid-state **AccuFreeze** control insures product consistency, worry-free operation and customer satisfaction.

HIGH RETURN ON INVESTMENT

Increased Profits – SaniServ machines combine efficiency with consistent product quality and fast quiet operation while insuring customer satisfaction with high profit ice cream or yogurt products.

QUALITY DESIGN

Durability – SaniServ machines are built to achieve long and dependable life through simplicity of design. Every machine is shipped standard with a stainless steel exterior, durable steel interior frame construction, heavy-duty components and consistency systems.

Model 521

Floor Model
Twist Soft Serv
Ice Cream / Yogurt Machine
With **AccuFreeze** Control



Made in USA

We reserve the right to change specifications and products design without notice. Such revisions do not entitle the buyer to corresponding changes, improvements, additions or replacements for previously purchased equipment

MODEL 521

Floor Model *Twist Soft Serv* / Yogurt Freezer

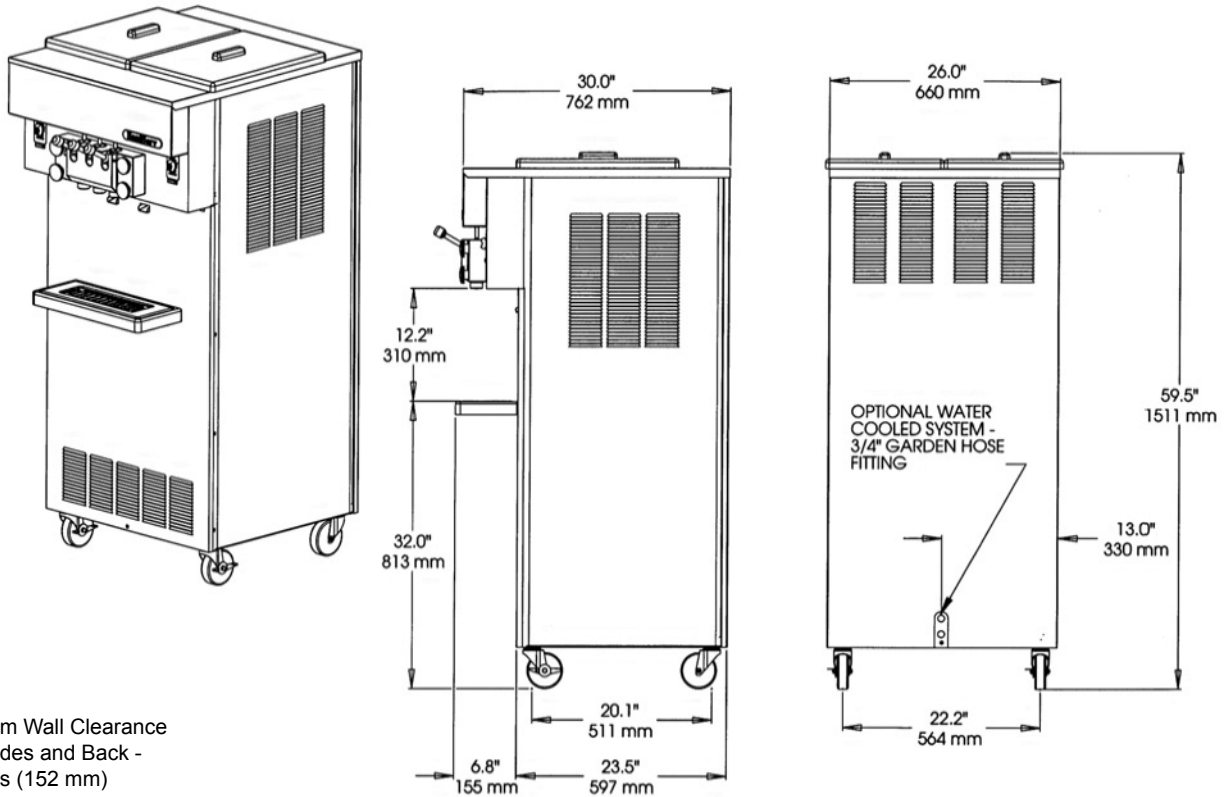

Minimum Wall Clearance
Both Sides and Back -
6 inches (152 mm)

ELECTRICAL				WIDTH	HEIGHT	DEPTH	WEIGHT	VOLUME
VOLTS	Hz	Ph.	Amps	INCHES (MM)	INCHES (MM)	INCHES (MM)	LBS. (Kg)	CU FT. (cu. m.)
208-230	60	1	20*	26 (660)	59.5 (1511)	30 (762)	603 (274)	
208-230	60	3	15*					
Shipping Specifications				36 (914)	65 (1650)	40 (1016)	634 (288)	54.8 (1.53)

* Two separate circuits required.

Specifications:

Cooling System:

Air or Water

Dasher and Compressor Motors:

(2) 1 HP Dashers
(2) 1 HP Compressors

Refrigerant Type:

R404A

Listings:

UL, cUL, NSF

Features:

Evaporator and Mix Reservoir

Capacity:

17 Quarts (16.15 liters) per side

Dasher:

Heavy-Duty Stainless Steel with low friction scraper blades.

Controls:

AccuFreeze solid-state control for accurate product consistency.

Solid State Audio/Visual Mix Out System with Compressor Lockout

Warranty:

Parts 1 year
Compressor 5 years
Evaporator 5 years

Options:

Tune Up Kit
Parts Tray
Syrup Rail
Water Cooled - 3/4" Garden Hose Fitting
Wash Out Kit - 3/8" Flare Fitting
Export Voltage



DESIGNED FOR HIGHER VOLUME APPLICATIONS

Seven – 4 oz. Servings per Minute per side and 17 Quart Capacity per side

IDEAL FOR SELF-SERV BUFFETS, CAFETERIAS, QUICK SERVICE RESTAURANTS

The **SaniServ** model 522 Soft Serv Freezer provides the highest volume of two individual flavors as well as a flavor twist. The 522 offers the highest volume of high profit, consistent quality Soft Serv and yogurt products in the SaniServ product lineup. Two large independent flavor product reservoirs and barrels guarantee separation of product and flavors. Always easy to operate, large product capacity and quick recovery time insure customers receive their favorite flavors individually or with a twist!

SPACE MAXIMIZING

Traditional Floor Model Design - SaniServ model 522 turns valuable floor space into a real profit center by serving the highest volume of two high profit ice cream and yogurt product flavors along with the ability to twist the flavors into a frozen favorite.

EASY CLEANING AND OPERATION

Fewer Parts = Simplified Cleaning – SaniServ equipment is designed and built with the fewer parts to be disassembled, cleaned and sanitized than any other machine in the industry. The state of the art solid-state **AccuFreeze** control insures product consistency, worry-free operation and customer satisfaction.

HIGH RETURN ON INVESTMENT

Increased Profits – SaniServ machines combine efficiency with consistent product quality and fast quiet operation while insuring customer satisfaction with high profit ice cream or yogurt products.

QUALITY DESIGN

Durability – SaniServ machines are built to achieve long and dependable life through simplicity of design. Every machine is shipped standard with a stainless steel exterior, durable steel interior frame construction, heavy-duty components and consistency systems.

Model 522

Floor Model
Twist Soft Serv
Ice Cream / Yogurt Machine
With **AccuFreeze** Control



Made in USA

We reserve the right to change specifications and products design without notice. Such revisions do not entitle the buyer to corresponding changes, improvements, additions or replacements for previously purchased equipment

MODEL 522

Floor Model *Twist Soft Serv / Yogurt Freezer*

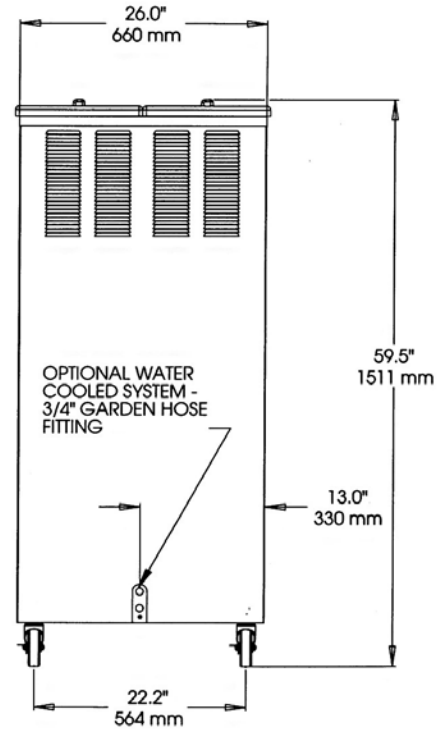
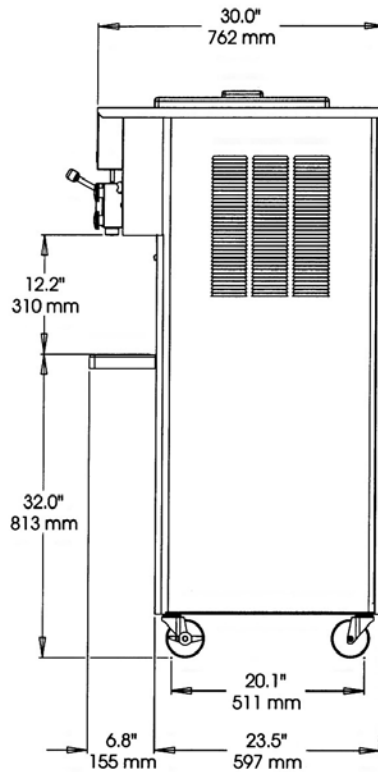
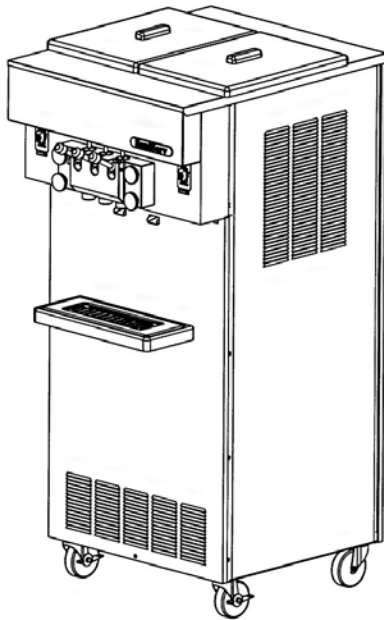

Minimum Wall Clearance
Both Sides and Back -
6 inches (152 mm)

ELECTRICAL				WIDTH	HEIGHT	DEPTH	WEIGHT	VOLUME
VOLTS	Hz	Ph.	Amps	INCHES (MM)	INCHES (MM)	INCHES (MM)	LBS. (Kg)	CU FT. (cu. m.)
208-230	60	1	30*	26 (660)	59.5 (1511)	30 (762)	603 (274)	
208-230	60	3	20*					
Shipping Specifications				36 (914)	65 (1650)	40 (1016)	634 (288)	54.8 (1.53)

* Two separate circuits required.

Specifications:

Cooling System:

Air or Water

Dasher and Compressor Motors:

- (2) 1 HP Dashers
- (2) 2 HP Compressor

Refrigerant Type:

R404A

Listings:

UL, cUL, NSF

Features:

Evaporator and Mix Reservoir

Capacity:

17 Quarts (16.15 liters) per side

Dasher:

Heavy-Duty Stainless Steel with low friction scraper blades.

Controls:

AccuFreeze solid-state control for accurate product consistency.

Solid State Audio/Visual Mix Out System with Compressor Lockout

Warranty:

- Parts 1 year
- Compressor 5 years
- Evaporator 5 years

Options:

- Tune Up Kit
- Parts Tray
- Syrup Rail
- Water Cooled - 3/4" Garden Hose Fitting
- Wash Out Kit - 3/8" Flare Fitting
- Export Voltage



DESIGNED FOR MEDIUM VOLUME APPLICATIONS

Two – 12 oz. Shakes per Minute – 20 Qt. Capacity

GREAT FOR RESTAURANTS AND BARS

The **SaniServ** model 608 Shake Freezer provides smooth quality, high profit shakes anytime, anywhere! Owners and operators can easily add high profit shakes to any menu and provide quality drinks everybody loves! By adding an optional Drink Spinner and a Syrup Rail for flavors, customers can also enjoy a wide flavor offering of quality shake products that keep them coming back for more of their own personal favorites! Also available in a Smoothie version.

SPACE SAVING

Small Footprint Design - SaniServ model 608 saves valuable floor space and turns the countertop into a real profit center by serving a large volume of high profit shake beverages.

EASY CLEANING AND OPERATION

Fewer Parts = Simplified Cleaning – SaniServ equipment is designed and built with the fewer parts to be disassembled, cleaned and sanitized than any other machine in the industry. The state of the art solid-state **AccuFreeze** control insures product consistency, worry-free operation and customer satisfaction.

HIGH RETURN ON INVESTMENT

Increased Profits – SaniServ machines combine efficiency with consistent product quality and fast quiet operation while insuring customer satisfaction with high profit ice cream or yogurt products.

QUALITY DESIGN

Durability – SaniServ machines are built to achieve long and dependable life through simplicity of design. Every machine is shipped standard with a stainless steel exterior, durable steel interior frame construction, heavy-duty components and consistency systems.

Model 608

Countertop

Shake Machine

With **AccuFreeze** control



Made in USA

We reserve the right to change specifications and products design without notice. Such revisions do not entitle the buyer to corresponding changes, improvements, additions or replacements for previously purchased equipment

MODEL 608

Counter Model Shake Freezer

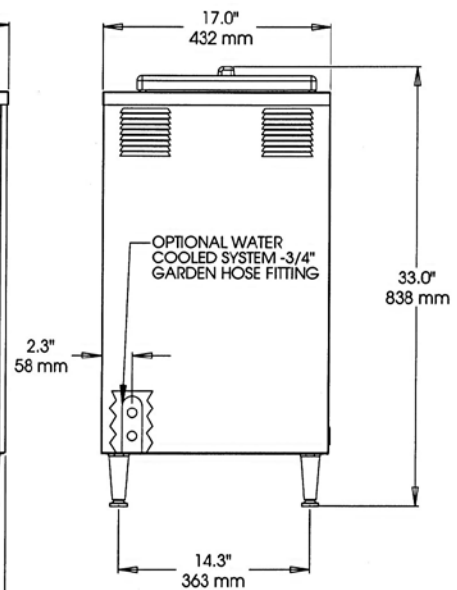
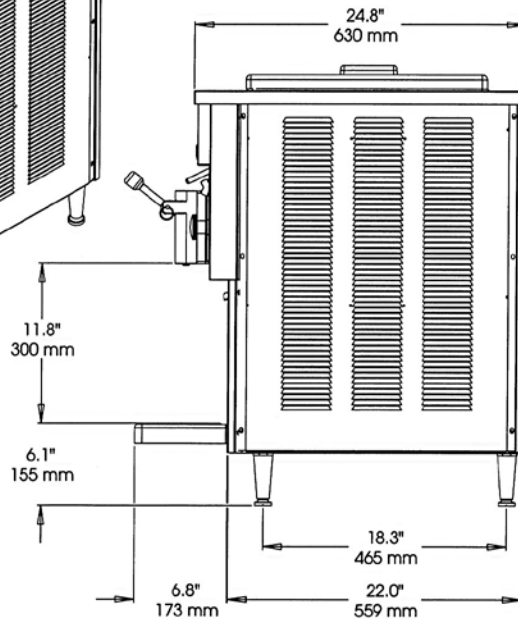
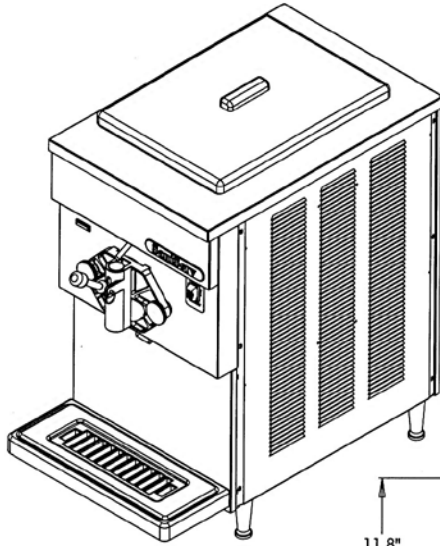

Minimum Wall Clearance
Both Sides and Back -
6 inches (152 mm)

ELECTRICAL				WIDTH	HEIGHT	DEPTH	WEIGHT	VOLUME
VOLTS	Hz	Ph.	Amps	INCHES (MM)	INCHES (MM)	INCHES (MM)	LBS. (Kg)	CU FT. (cu. m.)
115	60	1	15	17 (432)	33 (838)	24.8 (630)	208 (95)	
Shipping Specifications				22.5 (572)	41 (1042)	34.5 (876)	238 (108)	18.5 (.53)

Specifications:

Cooling System:
Air or Water

Dasher and Compressor Motors:
1/4 HP Dasher
3/4 HP Compressor

Refrigerant Type:
R404A

Listings:
UL, cUL, NSF

Features:

Evaporator and Mix Reservoir Capacity:
20 Quarts (18.9 liters)

Dasher:
Heavy-Duty Stainless Steel with low friction scraper blades.

Controls:
AccuFreeze solid-state control for accurate product consistency.

Solid State Audio/Visual Mix Out System with Compressor Lockout

Warranty:

Parts 1 year
Compressor 5 years
Evaporator 5 years

Options:

Tune Up Kit
Parts Tray
Syrup Rail
Counter Top Mounting Pad Machine Stand
Water Cooled - 3/4" Garden Hose Fitting
Wash Out Kit - 3/8" Flare Fitting
Export Voltages
Smoothie Version



DESIGNED FOR HIGHER VOLUME APPLICATIONS

Three – 12 oz. Shakes per Minute – 20 Qt. Capacity

GREAT FOR QUICK SERVICE RESTAURANTS AND DRIVE-THRU

The **SaniServ** model 601 Shake Freezer provides a high volume of smooth quality shakes! With its increased production and recovery time, owners and operators can always provide plenty of high profit shake product even during peak operating periods. As always, adding an optional Drink Spinner and Syrup Rail for flavors can create customer favorites. The 601 provides customer satisfaction every time by insuring their favorite shakes are always available!

SPACE SAVING

Small Footprint Design - SaniServ model 601 saves valuable floor space and turns the countertop into a real profit center by serving a large volume of high profit shake beverages.

EASY CLEANING AND OPERATION

Fewer Parts = Simplified Cleaning – SaniServ equipment is designed and built with fewer parts to be disassembled, cleaned and sanitized than any other machine in the industry. The state of the art solid-state **AccuFreeze** control insures product consistency, worry-free operation and customer satisfaction.

HIGH RETURN ON INVESTMENT

Increased Profits – SaniServ machines combine efficiency with consistent product quality and fast quiet operation while insuring customer satisfaction with high profit ice cream or yogurt products.

QUALITY DESIGN

Durability – SaniServ machines are built to achieve long and dependable life through simplicity of design. Every machine is shipped standard with a stainless steel exterior, durable steel interior frame construction, heavy-duty components and consistency systems.

Model 601

Countertop

Shake Machine

With **AccuFreeze** control



Made in USA

We reserve the right to change specifications and products design without notice. Such revisions do not entitle the buyer to corresponding changes, improvements, additions or replacements for previously purchased equipment

MODEL 601

Counter Model Shake Freezer

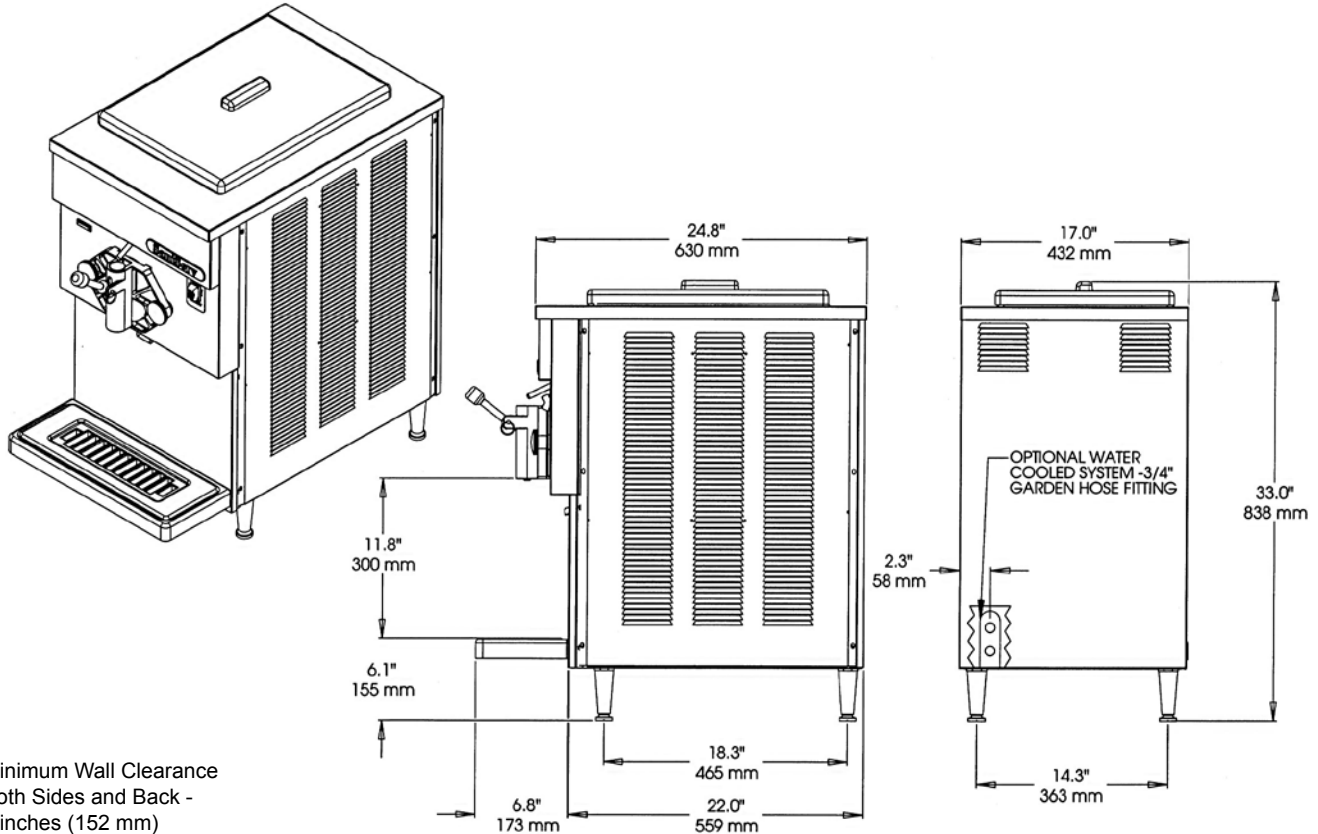

Minimum Wall Clearance
Both Sides and Back -
6 inches (152 mm)

ELECTRICAL				WIDTH	HEIGHT	DEPTH	WEIGHT	VOLUME
VOLTS	Hz	Ph.	Amps	INCHES (MM)	INCHES (MM)	INCHES (MM)	LBS. (Kg)	CU FT. (cu. m.)
208-230	60	1	20	17 (432)	33 (838)	24.8 (630)	242 (110)	
208-230	60	3	15					
Shipping Specifications				22.5 (572)	41 (1042)	34.5 (876)	269 (122)	18.5 (.53)

Specifications:

Cooling System:
Air or Water

Dasher and Compressor Motors:
1/4 HP Dasher
1 HP Compressor

Refrigerant Type:
R404A

Listings:
UL, cUL, NSF

Features:

Evaporator and Mix Reservoir
Capacity:
20 Quarts (18.9 liters)

Dasher:
Heavy-Duty Stainless Steel with low friction scraper blades.

Controls:
AccuFreeze solid-state control for accurate product consistency.

Solid State Audio/Visual Mix Out System with Compressor Lockout

Warranty:

Parts 1 year
Compressor 5 years
Evaporator 5 years

Options:

Tune Up Kit
Parts Tray
Syrup Rail
Counter Top Mounting Pad Machine Stand
Water Cooled - 3/4" Garden Hose Fitting
Wash Out Kit - 3/8" Flare Fitting
Export Voltages
Drink Spinner



DESIGNED FOR HIGHER VOLUME APPLICATIONS

Five – 16 oz. Servings per Minute – 20 Qt. Capacity

GREAT FOR RESTAURANTS, BUFFETS, & ICE CREAM SHOPS

The **SaniServ** model 614 Shake Freezer provides high profit, consistent quality shakes in a traditional single barrel flavor design! The 614 ease of operation is a favorite among owners and operators. The high production, capacity and recovery time insures the 614 is a perfect piece of equipment for satisfying customer demand. By adding a drink spinner and syrup rail, the 614 is sure to provide everyone's favorite shake flavor!

SPACE SAVING

Compact Floor Model Design - SaniServ provides a high volume of milk shake in the traditional floor model design. Operators can turn that valuable floor space into a high profit center by providing consistent high quality shakes customers demand.

EASY CLEANING AND OPERATION

Fewer Parts = Simplified Cleaning – SaniServ equipment is designed and built with the fewer parts to be disassembled, cleaned and sanitized than any other machine in the industry. The state of the art solid-state **AccuFreeze** control insures product consistency, worry-free operation and customer satisfaction.

HIGH RETURN ON INVESTMENT

Increased Profits – SaniServ machines combine efficiency with consistent product quality and fast quiet operation while insuring customer satisfaction with high profit ice cream or yogurt products.

QUALITY DESIGN

Durability – SaniServ machines are built to achieve long and dependable life through simplicity of design. Every machine is shipped standard with a stainless steel exterior, durable steel interior frame construction, heavy-duty components and consistency systems.

Model 614

Floor Model

Shake Machine

With **AccuFreeze** control



Made in USA

We reserve the right to change specifications and products design without notice. Such revisions do not entitle the buyer to corresponding changes, improvements, additions or replacements for previously purchased equipment

MODEL 614

Floor Model Shake Freezer

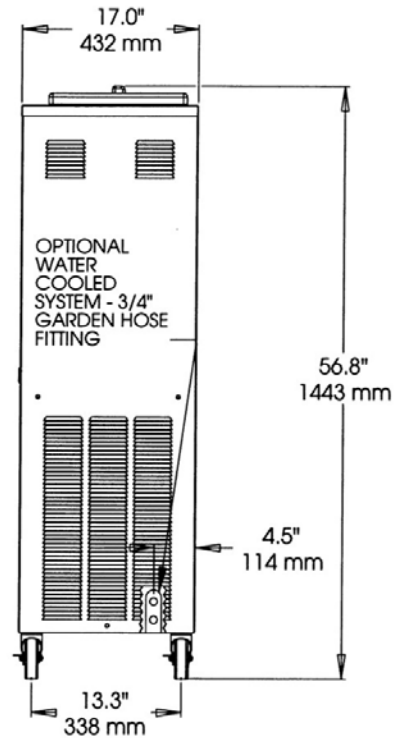
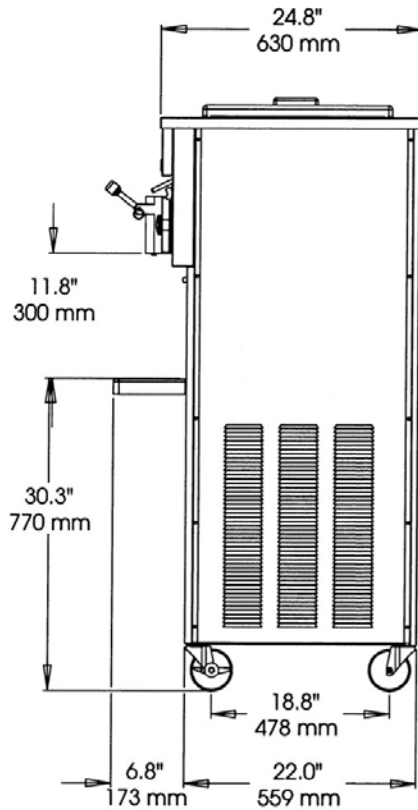
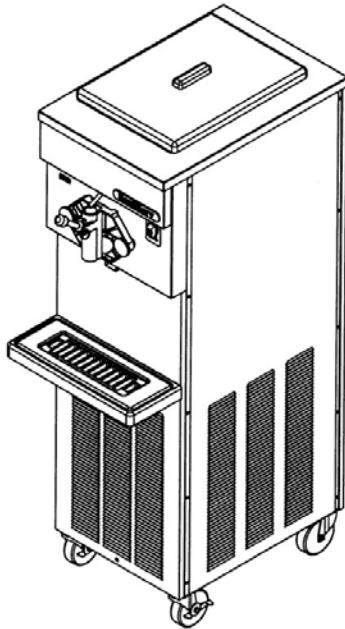

Minimum Wall Clearance
Both Sides and Back -
6 inches (152 mm)

ELECTRICAL				WIDTH	HEIGHT	DEPTH	WEIGHT	VOLUME
VOLTS	Hz	Ph.	Amps	INCHES (MM)	INCHES (MM)	INCHES (MM)	LBS. (Kg)	CU FT. (cu. m.)
208-230	60	1	25	17 (432)	56.5 (1435)	24.8 (630)	338 (153)	
208-230	60	3	20					
Shipping Specifications				24.5 (622)	58.1 (1476)	40.5 (1029)	380 (172)	32.4 (.92)

Specifications:

Cooling System:
Air or Water

Dasher and Compressor Motors:
1/4 HP Dasher
2 HP Compressor

Refrigerant Type:
R404A

Listings:
UL, cUL, NSF

Features:

Evaporator and Mix Reservoir Capacity:
20 Quarts (18.9 liters)

Dasher:
Heavy-Duty Stainless Steel with low friction scraper blades.

Controls:
AccuFreeze solid-state control for accurate product consistency.

Solid State Audio/Visual Mix Out System with Compressor Lockout

Warranty:

Parts 1 year
Compressor 5 years
Evaporator 5 years

Options:

Tune Up Kit
Parts Tray
Syrup Rail
Drink Spinner
Water Cooled - 3/4" Garden Hose Fitting
Wash Out Kit - 3/8" Flare Fitting



DESIGNED FOR HIGHER VOLUME APPLICATIONS

Five – 16 oz. Servings per Minute – 20 Qt. Capacity

GREAT FOR RESTAURANTS, BUFFETS, & ICE CREAM SHOPS

The **SaniServ** model 624 Floor Model Freezer provides not one but two favorite shake flavors in a high production floor model machine! The output and versatility of the 624 means owners and operators can choose two of their best sellers and because each side of the machine utilizes its own 2 HP refrigeration system, customers are always insured of getting their favorites! Add a pair of spinners for each side and the shake flavor choices are endless!

HEAVY DUTY

Floor Model Design - SaniServ model 624 provides a high volume of milk shakes in the traditional floor model design. Operators will enjoy the ease of operation and the ability to utilize the 624's versatility to provide the different types of shakes that customers enjoy!

EASY CLEANING AND OPERATION

Fewer Parts = Simplified Cleaning – SaniServ equipment is designed and built with the fewer parts to be disassembled, cleaned and sanitized than any other machine in the industry. The state of the art solid-state **AccuFreeze** control insures product consistency, worry-free operation and customer satisfaction.

HIGH RETURN ON INVESTMENT

Increased Profits – SaniServ machines combine efficiency with consistent product quality and fast quiet operation while insuring customer satisfaction with high profit ice cream or yogurt products.

QUALITY DESIGN

Durability – SaniServ machines are built to achieve long and dependable life through simplicity of design. Every machine is shipped standard with a stainless steel exterior, durable steel interior frame construction, heavy-duty components and consistency systems.

Model 624

Floor Model

Twin Flavor

Shake Machine

With AccuFreeze control



Made in USA

We reserve the right to change specifications and products design without notice. Such revisions do not entitle the buyer to corresponding changes, improvements, additions or replacements for previously purchased equipment

MODEL 624

Floor Model *Twin* Shake Freezer

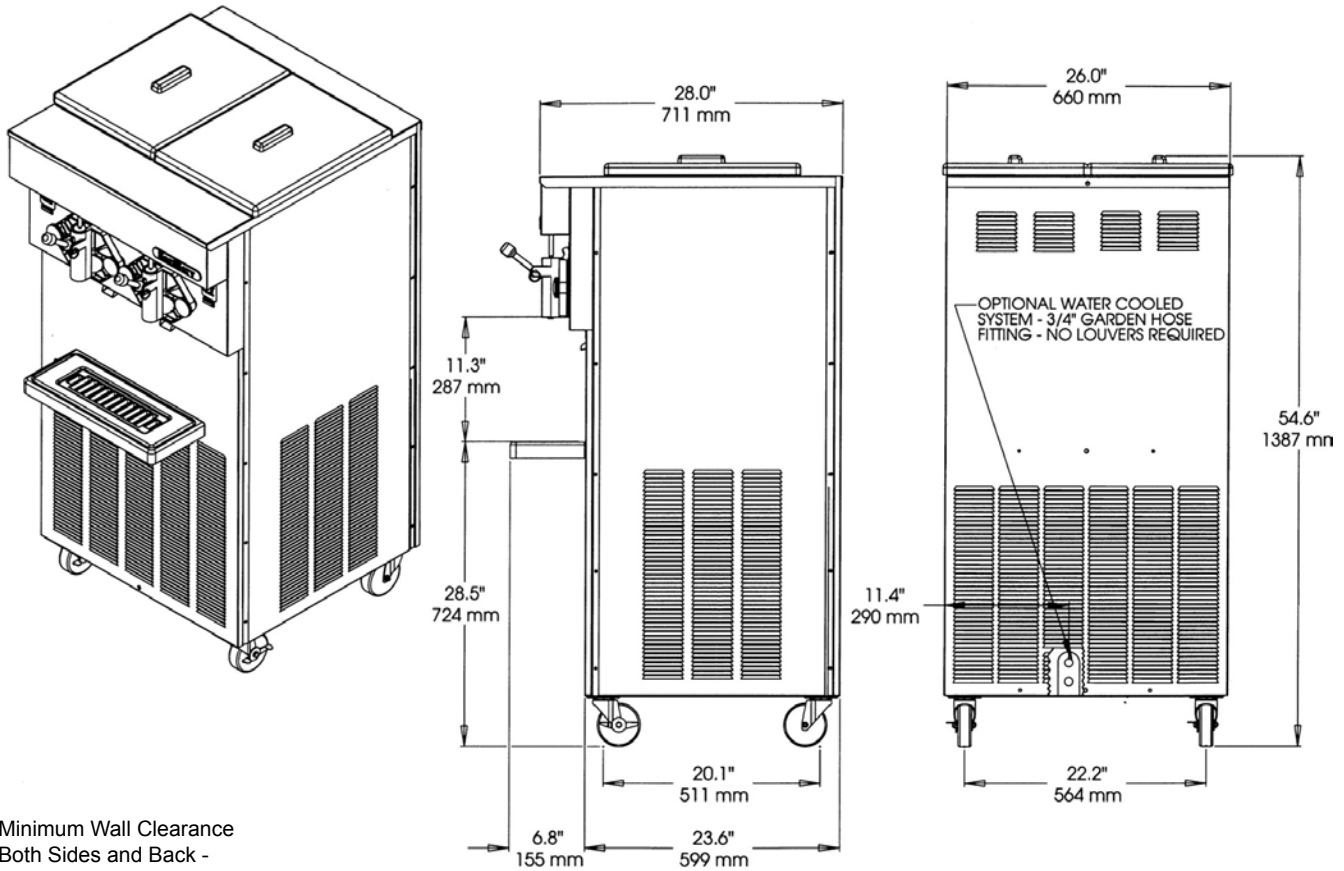

Minimum Wall Clearance
Both Sides and Back -
6 inches (152 mm)

ELECTRICAL				WIDTH	HEIGHT	DEPTH	WEIGHT	VOLUME
VOLTS	Hz	Ph.	Amps	INCHES (MM)	INCHES (MM)	INCHES (MM)	LBS. (Kg)	CU FT. (cu. m.)
208-230	60	1	2x25	26 (660)	54.6 (1387)	28 (711)	575 (261)	
208-230	60	3	2x20					
Shipping Specifications				37 (940)	60 (1524)	41 (1024)	633 (287)	52.7 (1.49)

Specifications:

Cooling System:
Air or Water

Dasher and Compressor Motors:
(2) 1/4 HP Dasher
(2) 2 HP Compressor

Refrigerant Type:
R404A

Listings:
UL, cUL, NSF

Features:

Evaporator and Mix Reservoir Capacity:
20 Quarts (18.9 liters)

Dasher:
Heavy-Duty Stainless Steel with low friction scraper blades.

Controls:
AccuFreeze solid-state control for accurate product consistency.

Solid State Audio/Visual Mix Out System with Compressor Lockout

Warranty:

Parts 1 year
Compressor 5 years
Evaporator 5 years

Options:

Tune Up Kit
Parts Tray
Syrup Rail
Drink Spinner
Water Cooled - 3/4" Garden Hose Fitting
Wash Out Kit - 3/8" Flare Fitting
Export Voltages



DESIGNED FOR HIGHER VOLUME APPLICATIONS

Three – 12 oz. Shakes per Minute – 20 Qt. Capacity

GREAT FOR QUICK SERVICE RESTAURANTS AND DRIVE-THRU'S

The **SaniServ** Model 601SAS Shake Freezer provides up to four flavors of uniform, smooth, high profit shakes! The 601SAS automatically mixes each shake uniformly to insure a perfect milk shake in the flavor desired! Owners and operators will appreciate the machine's quick recovery time and ability to provide everyone's favorite flavor quickly even during peak operating periods! The 601SAS can satisfy everyone with their favorite flavor every time!

SPACE SAVING

Small Footprint Design - SaniServ model 601SAS saves valuable floor space and turns the countertop into a real profit center by serving a large volume of high profit shake beverages in four flavors of your choice.

EASY CLEANING AND OPERATION

Fewer Parts = Simplified Cleaning – SaniServ equipment is designed and built with the fewer parts to be disassembled, cleaned and sanitized than any other machine in the industry.

HIGH RETURN ON INVESTMENT

Increased Profits – SaniServ machines combine efficiency with consistent product quality and fast quiet operation while insuring customer satisfaction with high profit ice cream or yogurt products.

QUALITY DESIGN

Durability – SaniServ machines are built to achieve long and dependable life through simplicity of design. Every machine is shipped standard with a stainless steel exterior, durable steel interior frame construction, heavy-duty components and consistency systems.

Model 601SAS

Countertop
Select-A-Shake Machine



Made in USA

We reserve the right to change specifications and products design without notice. Such revisions do not entitle the buyer to corresponding changes, improvements, additions or replacements for previously purchased equipment

MODEL 601SAS

Counter Model Shake Freezer

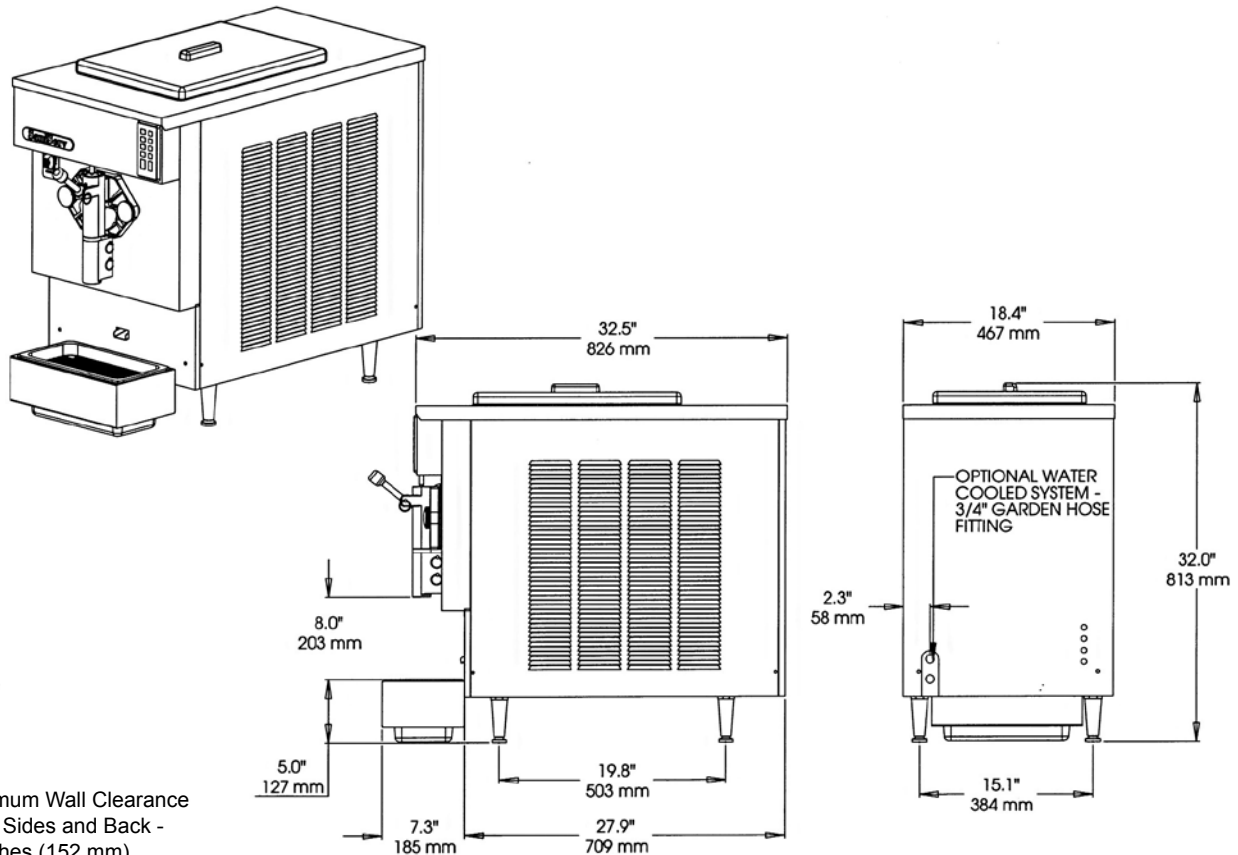

Minimum Wall Clearance
Both Sides and Back -
6 inches (152 mm)

ELECTRICAL				WIDTH	HEIGHT	DEPTH	WEIGHT	VOLUME
VOLTS	Hz	Ph.	Amps	INCHES (MM)	INCHES (MM)	INCHES (MM)	LBS. (Kg)	CU FT. (cu. m.)
208-230	60	1	20	18.4 (467)	32(813)	32.5 (826)	270(122)	
208-230	60	3	15					
Shipping Specifications				24.5 (622)	36.0 (914)	40.5 (1028)	300 (136)	20.7 (.57)

Specifications:

Cooling System:

Air or Water

Dasher and Compressor Motors:

1/2 HP Dasher
1 HP Compressor

Refrigerant Type:

R404A

Listings:

UL, cUL, NSF

This unit requires CO2 connection and a water line connection. The unit comes with 10' syrup line, (3) three gallon canisters, and one regulator.

Features:

Evaporator and Mix Reservoir

Capacity:
20 Quarts (18.9 liters)

Dasher:

Heavy-Duty Stainless Steel with low friction scraper blades.

Controls:

Automatic consistency controls for improved consistency.

Tamper Proof Automatic Visual Mix Out System

Warranty:

Parts 1 year
Compressor 5 years
Evaporator 5 years

Options:

Tune Up Kit
Parts Tray
Syrup Rail
Counter Top Mounting Pad Machine Stand
Water Cooled - 3/4" Garden Hose Fitting
Wash Out Kit - 3/8" Flare Fitting
Export Voltages



DESIGNED FOR HIGHER VOLUME APPLICATIONS

Five – 16 oz. Servings per Minute – 20 Qt. Capacity

GREAT FOR RESTAURANTS, BUFFETS, & ICE CREAM SHOPS

The **SaniServ** Model 614SAS Shake Freezer provides up to four flavors of uniform, smooth, high profit shakes! The 614SAS automatically mixes each shake uniformly to insure a perfect milk shake in the flavor desired! Owners and operators will appreciate the machine's quick recovery time and ability to provide everyone's favorite flavor quickly even during peak operating periods! The 614SAS can satisfy everyone with their favorite flavor every time!

SPACE SAVING

Compact Floor Model Design - SaniServ model 614SAS provides a high volume of milk shake in the traditional floor model design. Operators can turn that valuable floor space into a high profit center by providing consistent high quality shakes customers demand.

EASY CLEANING AND OPERATION

Fewer Parts = Simplified Cleaning – SaniServ equipment is designed and built with the fewer parts to be disassembled, cleaned and sanitized than any other machine in the industry.

HIGH RETURN ON INVESTMENT

Increased Profits – SaniServ machines combine efficiency with consistent product quality and fast quiet operation while insuring customer satisfaction with high profit ice cream or yogurt products.

QUALITY DESIGN

Durability – SaniServ machines are built to achieve long and dependable life through simplicity of design. Every machine is shipped standard with a stainless steel exterior, durable steel interior frame construction, heavy-duty components and consistency systems.

Model 614SAS

Floor Model
Select-A-Shake Machine



Made in USA

We reserve the right to change specifications and products design without notice. Such revisions do not entitle the buyer to corresponding changes, improvements, additions or replacements for previously purchased equipment

MODEL 614SAS

Floor Model Shake Freezer

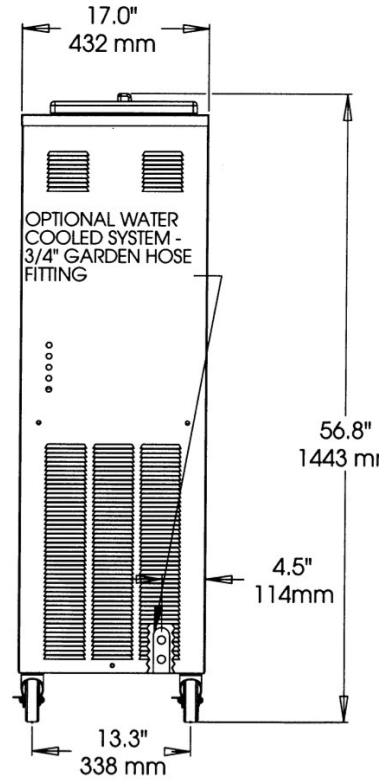
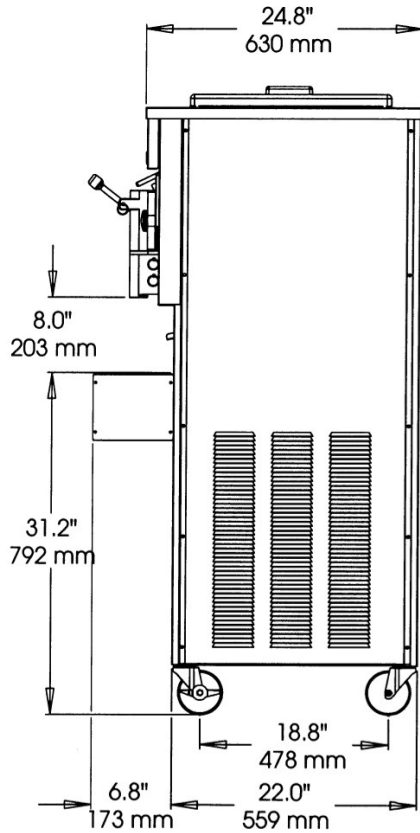
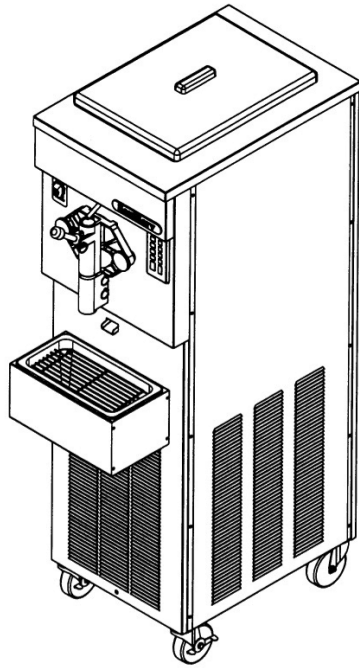

Minimum Wall Clearance
Both Sides and Back -
6 inches (152 mm)

ELECTRICAL				WIDTH	HEIGHT	DEPTH	WEIGHT	VOLUME
VOLTS	Hz	Ph.	Amps	INCHES (MM)	INCHES (MM)	INCHES (MM)	LBS. (Kg)	CU FT. (cu. m.)
208-230	60	1	25	17 (432)	56.8 (1443)	24.8 (630)	352 (153)	
208-230	60	3	20					
Shipping Specifications				24.5 (622)	58.1 (1476)	40.5 (1028)	382 (173)	32.5 (.92)

Specifications:

Cooling System:

Air or Water

Dasher and Compressor Motors:

1/2 HP Dasher
2 HP Compressor

Refrigerant Type:

R404A

Listings:

UL, cUL, NSF

This unit requires CO2 connection and a water line connection. The unit comes with 10' syrup line, (3) three gallon canisters, and one regulator.

Features:

Evaporator and Mix Reservoir

Capacity:
20 Quarts (18.9 liters)

Dasher:

Heavy-Duty Stainless Steel with low friction scraper blades.

Controls:

Automatic consistency controls for improved consistency.

Tamper Proof Automatic Visual Mix Out System

Warranty:

Parts 1 year
Compressor 5 years
Evaporator 5 years

Options:

Tune Up Kit
Parts Tray
Syrup Rail
Drink Spinner
Water Cooled - 3/4" Garden Hose Fitting
Wash Out Kit - 3/8" Flare Fitting



DESIGNED FOR MEDIUM VOLUME APPLICATIONS

Three - 12oz. shakes per minute per side – 14 Qt. Capacity

OFFER TWO DIFFERENT FLAVORS IN ONE MACHINE!

The **SaniServ** model 691 Countertop Shake Freezer can provide two frozen beverage favorites in one machine! With an independent drive system in each side of the machine, product can be easily maintained and or changed in either side when desired! The mix pan is also refrigerated to ensure quicker recovery time. By offering not one, but two flavor products, owners and operators will insure every customer stays satisfied and increase their operating profits!

SPACE SAVING

Small Footprint Design - SaniServ model 691 provides two frozen beverage flavors in a countertop model design. Operators will enjoy the ease of operation and the versatility to offer two different types of frozen beverages that customers desire at the same time!

EASY CLEANING AND OPERATION

Fewer Parts = Simplified Cleaning – SaniServ equipment is designed and built with the fewer parts to be disassembled, cleaned and sanitized than any other machine in the industry. The state of the art solid-state **AccuFreeze** control insures product consistency, worry-free operation and customer satisfaction.

HIGH RETURN ON INVESTMENT

Increased Profits – SaniServ machines combine affordable efficiency with consistent product quality and fast quiet operation to insure customer satisfaction with high profit frozen beverages.

QUALITY DESIGN

Durability – SaniServ machines are built to achieve long and dependable life through simplicity of design. Every machine is shipped standard with a stainless steel exterior, durable steel interior frame construction, heavy-duty components and consistency systems.

Model 691

Twin Flavor Counter
Shake Machine
With **AccuFreeze** Control



Made in USA

We reserve the right to change specifications and products design without notice. Such revisions do not entitle the buyer to corresponding changes, improvements, additions or replacements for previously purchased equipment

MODEL 691

Counter Model Shake Freezer

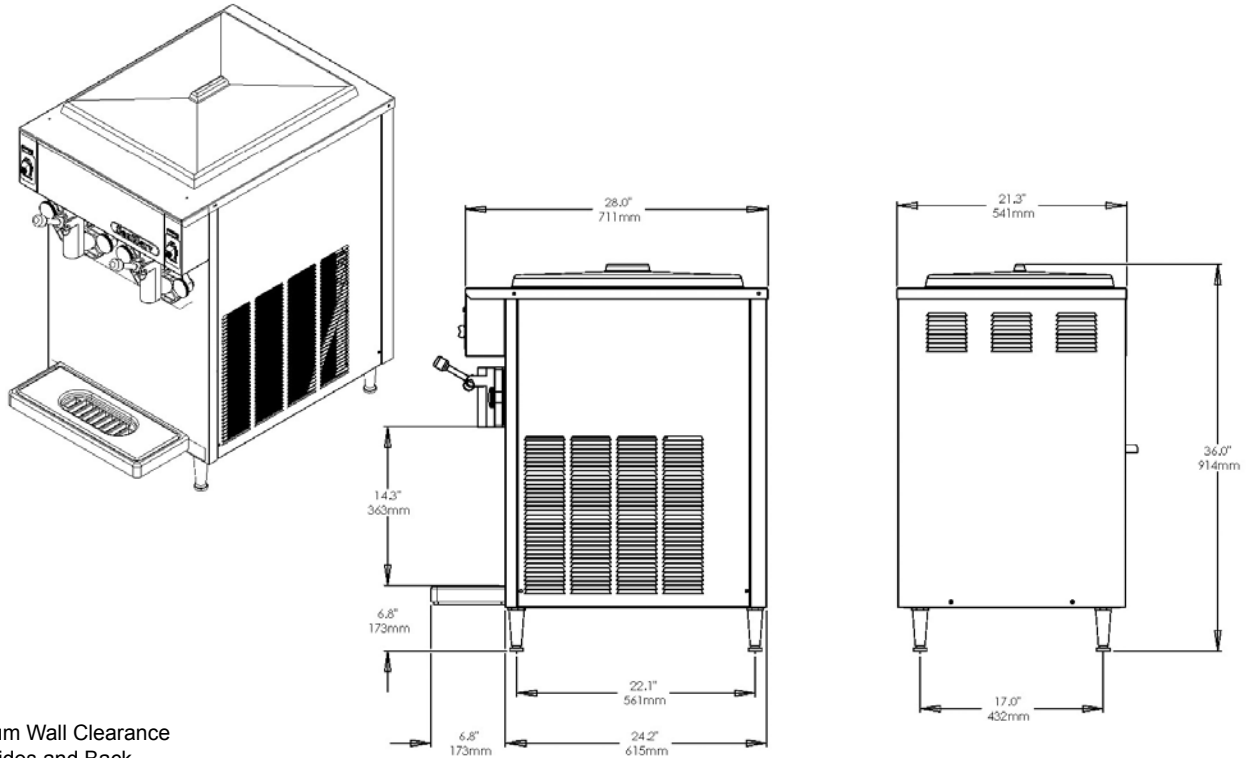

Minimum Wall Clearance
Both Sides and Back -
6 inches (152 mm)

ELECTRICAL				WIDTH	HEIGHT	DEPTH	WEIGHT	VOLUME
VOLTS	Hz	Ph.	Amps	INCHES (MM)	INCHES (MM)	INCHES (MM)	LBS. (Kg)	CU FT. (cu. m.)
208-230	60	1	20	21.3 (541)	36 (914)	28 (711)	249 (118)	
208-230	60	3	15					
Shipping Specifications				31.5 (800)	36.5 (927)	40.5 (1029)	330 (150)	29.6 (.83)

Specifications:

Cooling System:
Air Only

Dasher and Compressor Motors:

(2) 1/4 HP Dashers
(1) 1 HP Compressor

Refrigerant Type:
R404A

Listings:
UL, NSF

Features:

Evaporator and Mix Reservoir Capacity:
14 Quarts (13.2 liters)

Dasher:
Heavy-Duty Stainless Steel with low friction scraper blades.

Controls:
AccuFreeze solid-state control for accurate product consistency.

Solid State Audio/Visual Mix Out System with Compressor Lockout

Warranty:

Parts 1 year
Compressor 5 years
Evaporator 5 years

Options:

Tune Up Kit Parts Tray
Drink Spinner Syrup Rail
Auto-fill Machine Stand
Export Voltage
Remote Condenser*

* Requires a remote condensing unit (condenser & compressor) connected by two refrigeration lines.



DESIGNED FOR HIGHER VOLUME APPLICATIONS

**Seven – 4 oz. Cones & Five - 16 oz. Shakes per Minute
and 20 Quart Capacity per side!**

GREAT FOR ICE CREAM SHOPS, CAFETERIAS, COMMISSARIES

The **SaniServ** Model 824 Twin Flavor Soft Serv Freezer can provide not one but two favorite high profit, consistent quality Soft Serv and shake products in a dual barrel design! The ease of the model 824's operation and product versatility is a favorite among owners and operators. The high production, capacity and recovery time insures the 824 is a perfect piece of equipment for satisfying enough of any two customer favorite frozen treats at any time! Add a Syrup Rail and Drink Spinner to offer a wide variety of products like malts, sundaes, ice cream treats with add-ins and cones.

HEAVY DUTY

Traditional Floor Model Design - SaniServ model 824 provides a high volume of two flavors of Soft Serv and shake products in the traditional floor model design. Operators can turn that valuable floor space into a high profit center by providing two frozen favorite treats customers enjoy!

EASY CLEANING AND OPERATION

Fewer Parts = Simplified Cleaning – SaniServ equipment is designed and built with the fewer parts to be disassembled, cleaned and sanitized than any other machine in the industry. The state of the art solid-state **AccuFreeze** control insures product consistency, worry-free operation and customer satisfaction.

HIGH RETURN ON INVESTMENT

Increased Profits – SaniServ machines combine efficiency with consistent product quality and fast quiet operation while insuring customer satisfaction with high profit ice cream or yogurt products.

QUALITY DESIGN

Durability – SaniServ machines are built to achieve long and dependable life through simplicity of design. Every machine is shipped standard with a stainless steel exterior, durable steel interior frame construction, heavy-duty components and consistency systems.

Model 824

Floor Model

**Soft Serv Ice Cream
and Shake Machine
With AccuFreeze Control**



Made in USA

We reserve the right to change specifications and products design without notice. Such revisions do not entitle the buyer to corresponding changes, improvements, additions or replacements for previously purchased equipment

MODEL 824

Floor Model *Twin* Shake Freezer

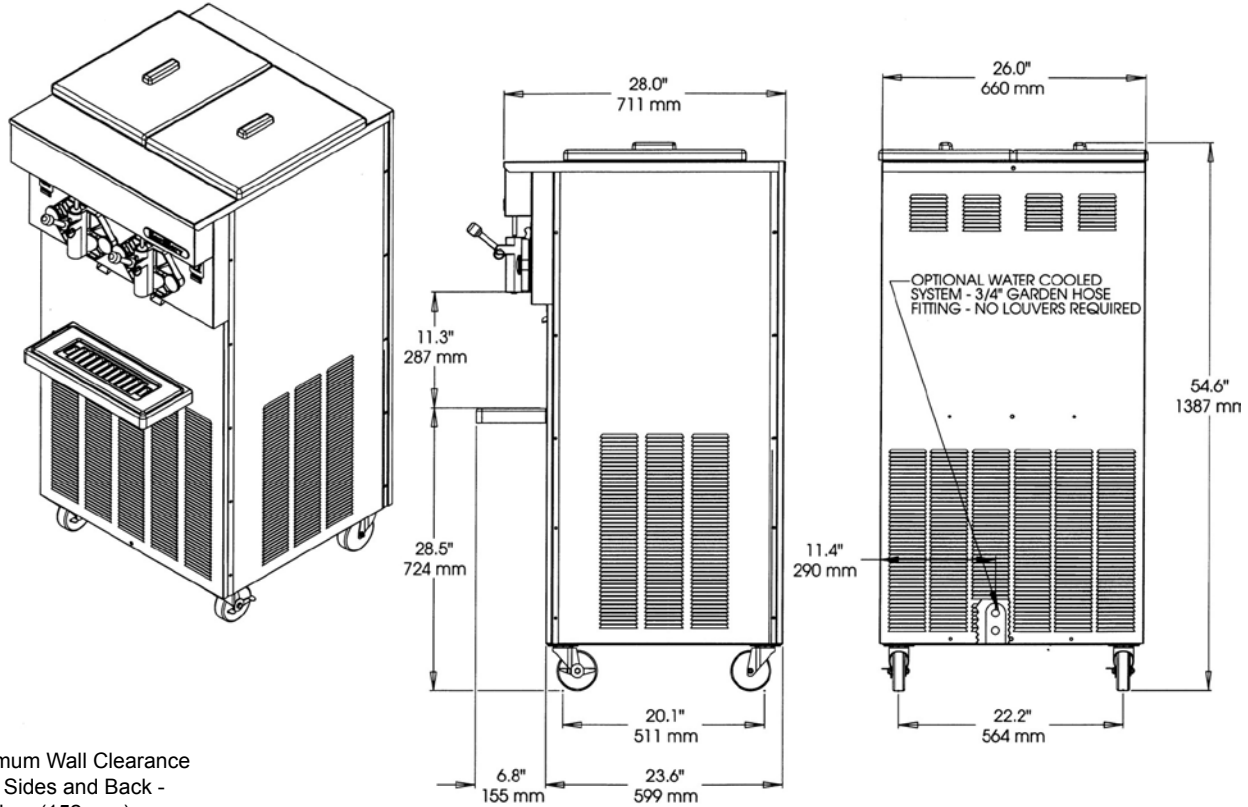

Minimum Wall Clearance
Both Sides and Back -
6 inches (152 mm)

ELECTRICAL				WIDTH	HEIGHT	DEPTH	WEIGHT	VOLUME
VOLTS	Hz	Ph.	Amps	INCHES (MM)	INCHES (MM)	INCHES (MM)	LBS. (Kg)	CU FT. (cu. m.)
208-230	60	1	(1) 25 (1) 30 *	26 (660)	54.6 (1387)	28 (711)	575 (261)	
208-230	60	3	20*					
Shipping Specifications				37 (940)	60 (1524)	41 (1024)	602 (273)	52.7 (1.49)

* Two separate circuits required.

Specifications:

Cooling System:
Air or Water

Dasher and Compressor Motors:

- (1) ¼ HP Dasher Shake
- (1) 1 HP Dasher Soft Serv
- (2) 2 HP Compressor

Refrigerant Type:
R404A

Features:

Evaporator and Mix Reservoir Capacity:
20 Quarts (18.9 liters)

Dasher:
Heavy-Duty Stainless Steel with low friction scraper blades.

Controls:
AccuFreeze solid-state control for accurate product consistency.

Solid State Audio/Visual Mix Out System with Compressor Lockout

Warranty:

Parts 1 year
Compressor 5 years
Evaporator 5 years

Options:

Tune Up Kit
Parts Tray
Syrup Rail
Drink Spinner
Water Cooled -3/4" Garden Hose Fitting
Wash Out Kit -3/8" Flare Fitting
Export Voltages



DESIGNED FOR MEDIUM VOLUME APPLICATIONS

4 Gal per Hour & 14 Qt Capacity per side

OFFER TWO DIFFERENT FLAVORS IN ONE MACHINE!

MAXIMIZE YOUR PROFITS

Combine efficiency with consistent product quality and fast quiet operation to insure customer satisfaction with one Milk Shake flavor and one Frozen Beverage flavor.

ADD TO YOUR PRODUCT OFFERING

You can offer Milk Shakes and fruit flavor slush, frozen lemonade, Fresh fruit and yogurt based smoothies, frozen cocktails like Margaritas, Pina Coladas and Daiquiri's. This 115 volt unit is easily added to your operation.

FAST SERVICE

Designed for the most demanding high volume operations. Just pull the spigot handle to dispense the ready to consume product, up to two 8-oz. servings per minute, per side.

HIGH VOLUME OF PRODUCT

The model 808 produces up to 4 gallons of frozen beverages per hour, and 4 gallons of milk shake product per hour. Each evaporator and mix pan holds 14 quarts of product. You will have product available even during peak periods.

REFRIGERATED MIX PANS

Meets NSF Code 7 for dairy and non-dairy based products. Keeps product in mix pans below 40 degrees

INDEPENDENT DRIVE SYSTEM

Allows you to operate each side of the machine independently. Provide flexibility to meet demand during slow and busy periods.

STATE OF THE ART CONTROL SYSTEM

Solid State **AccuFreeze** Control with tamper proof mix out system alerts the operator with an audio/visual alarm when product in the mix reservoir is low and needs to be replenished.

FAST, EASY, CLEAN

SaniServ equipment is design to be easily cleaned and sanitized, with the fewest parts possible for rapid assembly and disassembly.

INVEST IN EQUIPMENT BUILT TO LAST

SaniServ frozen beverage machines achieve long and dependable life through simplicity of design, durable steel frame construction and heavy duty components. Shipped standard with stainless steel exterior.

Model 808

Counter Model Combination
**Shake and Frozen
Beverage Machine**
With **AccuFreeze Control**



Made in USA

We reserve the right to change specifications and products design without notice. Such revisions do not entitle the buyer to corresponding changes, improvements, additions or replacements for previously purchased equipment

MODEL 808

Counter Model Combination Shake and Frozen Beverage Machine

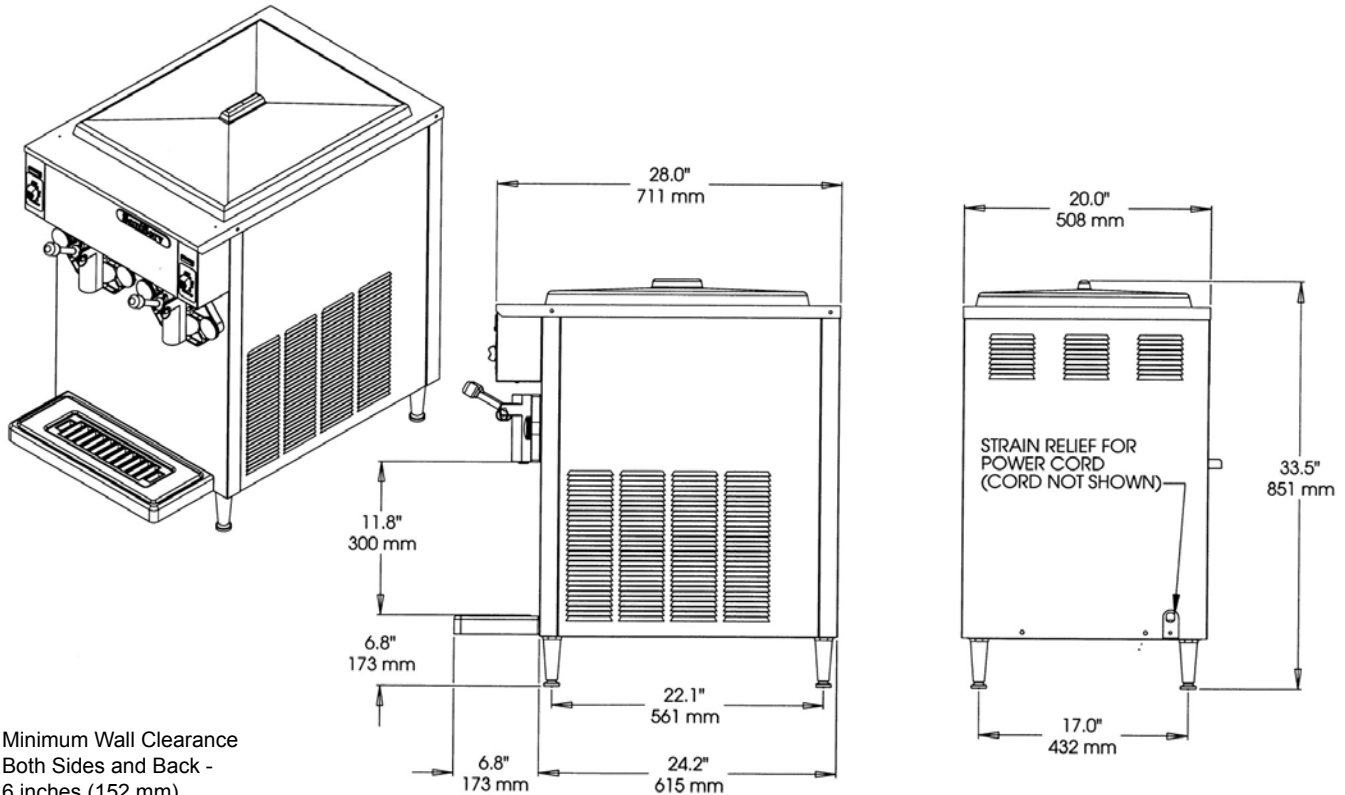

Minimum Wall Clearance
Both Sides and Back -
6 inches (152 mm)

ELECTRICAL				WIDTH	HEIGHT	DEPTH	WEIGHT	VOLUME
VOLTS	Hz	Ph.	Amps	INCHES (MM)	INCHES (MM)	INCHES (MM)	LBS. (Kg)	CU FT. (cu. m.)
115	60	1	15	20 (508)	33.5 (851)	28 (711)	234 (106)	
Shipping Specifications				31.5 (800)	36.5 (927)	40.5 (1029)	315 (143)	29.6 (.83)

Specifications:

Cooling System:
Air Only

Dasher and Compressor Motors:

(2) 1/4 HP Dashers
(1) 3/4 HP Compressor

Refrigerant Type:
R404A

Listings:
UL, NSF

Features:

Evaporator and Mix Reservoir Capacity:
14 Quarts (13.2 liters)

Dasher:
Heavy-Duty Stainless Steel with low friction scraper blades.

Controls:
AccuFreeze solid-state control for accurate product consistency.

Solid State Audio/Visual Mix Out System with Compressor Lockout

Warranty:

Parts 1 year
Compressor 5 years
Evaporator 5 years

Options:

Tune Up Kit Parts Tray
Drink Spinner Syrup Rail
Auto-fill Machine Stand
Export Voltage
Remote Condenser*

* Requires a remote condensing unit (condenser & compressor) connected by two refrigeration lines.



DESIGNED FOR MEDIUM VOLUME APPLICATIONS

8 Gallons per Hour – 20 Quart Capacity

HIGH CAPACITY WITH 110 VOLT CONVENIENCE!

The **SaniServ** model 707 Frozen Beverage Freezer is a customer favorite! Its sleek single barrel profile has the ability to offer many types of slush beverages! Choose from frozen margaritas and daiquiris to frozen fruit flavor drinks such as frozen lemonade and fruit smoothies. The 707 is a must have for the customer looking for an affordable way to offer all of their favorite beverages frozen!

SPACE SAVING

Small Footprint Design - SaniServ Save valuable floor space and turn the bar or countertop into a real profit center. By offering the finest quality of frozen drinks each time, every frozen beverage is consistent from the first to the last!

EASY CLEANING AND OPERATION

Fewer Parts = Simplified Cleaning – SaniServ equipment is designed and built with the fewer parts to be disassembled, cleaned and sanitized than any other machine in the industry. The state of the art solid-state **AccuFreeze** control insures product consistency, worry-free operation and customer satisfaction.

HIGH RETURN ON INVESTMENT

Increased Profits – SaniServ machines combine affordable efficiency with consistent product quality and fast quiet operation to insure customer satisfaction with high profit frozen beverages.

QUALITY DESIGN

Durability – SaniServ machines are built to achieve long and dependable life through simplicity of design. Every machine is shipped standard with a stainless steel exterior, durable steel interior frame construction, heavy-duty components and consistency systems.

Model 707

Countertop
Frozen Beverage Machine
With **AccuFreeze** Control



Made in USA

We reserve the right to change specifications and products design without notice. Such revisions do not entitle the buyer to corresponding changes, improvements, additions or replacements for previously purchased equipment

MODEL 707

Counter Model Frozen Beverage/Cocktail Freezer

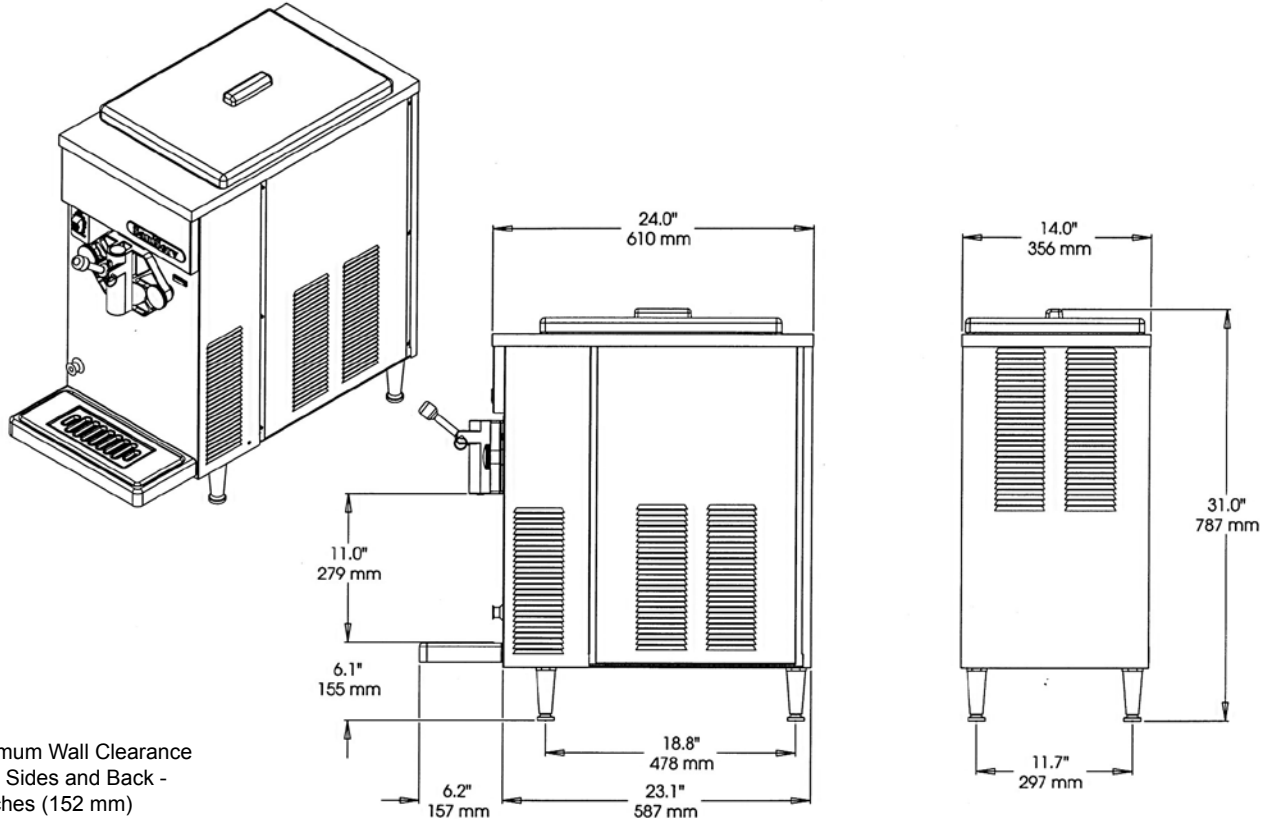

Minimum Wall Clearance
Both Sides and Back -
6 inches (152 mm)

ELECTRICAL				WIDTH	HEIGHT	DEPTH	WEIGHT	VOLUME
VOLTS	Hz	Ph.	Amps	INCHES (MM)	INCHES (MM)	INCHES (MM)	LBS. (Kg)	CU FT. (cu. m.)
115	60	1	15	14 (356)	31 (787)	24 (610)	159 (72)	
Shipping Specifications				22.5 (572)	33.5 (851)	34.5 (876)	176 (80)	18.1 (.51)

Specifications:

Cooling System:
Air Only

Dasher and Compressor Motors:

1/4 HP Dasher
1/2 HP Compressor

Refrigerant Type:

R404A

Listings:

UL, NSF

Features:

Evaporator and Mix Reservoir
Capacity:
20 Quarts (18.9 liters)

Dasher:

Heavy-Duty Stainless Steel with low friction scraper blades.

Controls:

AccuFreeze solid-state control for accurate product consistency.

Solid State Audio/Visual Mix Out System with Compressor Lockout

Warranty:

Parts 1 year
Compressor 5 years
Evaporator 5 years

Options:

Tune Up Kit
Parts Tray
Drink Spinner
Syrup Rail
Counter Top Mounting Pad Machine Stand
Wash Out Kit – 3/8" Flare Fitting
Export Voltage



DESIGNED FOR MEDIUM VOLUME APPLICATIONS

10 Gallons per Hour – 20 Quart Capacity

HIGH CAPACITY WITH 115 VOLT CONVENIENCE!

The **SaniServ** model 708 Frozen Beverage Freezer is an industry workhorse! The 708 provides a great way to offer many types of slush beverage! Choose from frozen margaritas and daiquiri's to frozen fruit flavor drinks, frozen lemonade and smoothies. The 708 also provides a way to serve a greater volume of all of your favorite frozen drinks without the need for an additional costly power supply!

SPACE SAVING

Small Footprint Design - Save valuable floor space and turn the bar or countertop into a real profit center. By offering the finest quality of frozen drinks each time, every frozen beverage is consistent from the first to the last!

EASY CLEANING AND OPERATION

Fewer Parts = Simplified Cleaning – **SaniServ** equipment is designed and built with the fewer parts to be disassembled, cleaned and sanitized than any other machine in the industry. The state of the art solid-state **AccuFreeze** control insures product consistency, worry-free operation and customer satisfaction.

HIGH RETURN ON INVESTMENT

Increased Profits – **SaniServ** machines combine affordable efficiency with consistent product quality and fast quiet operation to insure customer satisfaction with high profit frozen beverages.

QUALITY DESIGN

Durability – **SaniServ** machines are built to achieve long and dependable life through simplicity of design. Every machine is shipped standard with a stainless steel exterior, durable steel interior frame construction, heavy-duty components and consistency systems.

Model 708

Countertop

**Frozen Beverage Machine
With AccuFreeze Control**



Made in USA

We reserve the right to change specifications and products design without notice. Such revisions do not entitle the buyer to corresponding changes, improvements, additions or replacements for previously purchased equipment



MODEL 708

Counter Model Frozen Beverage/Cocktail Freezer

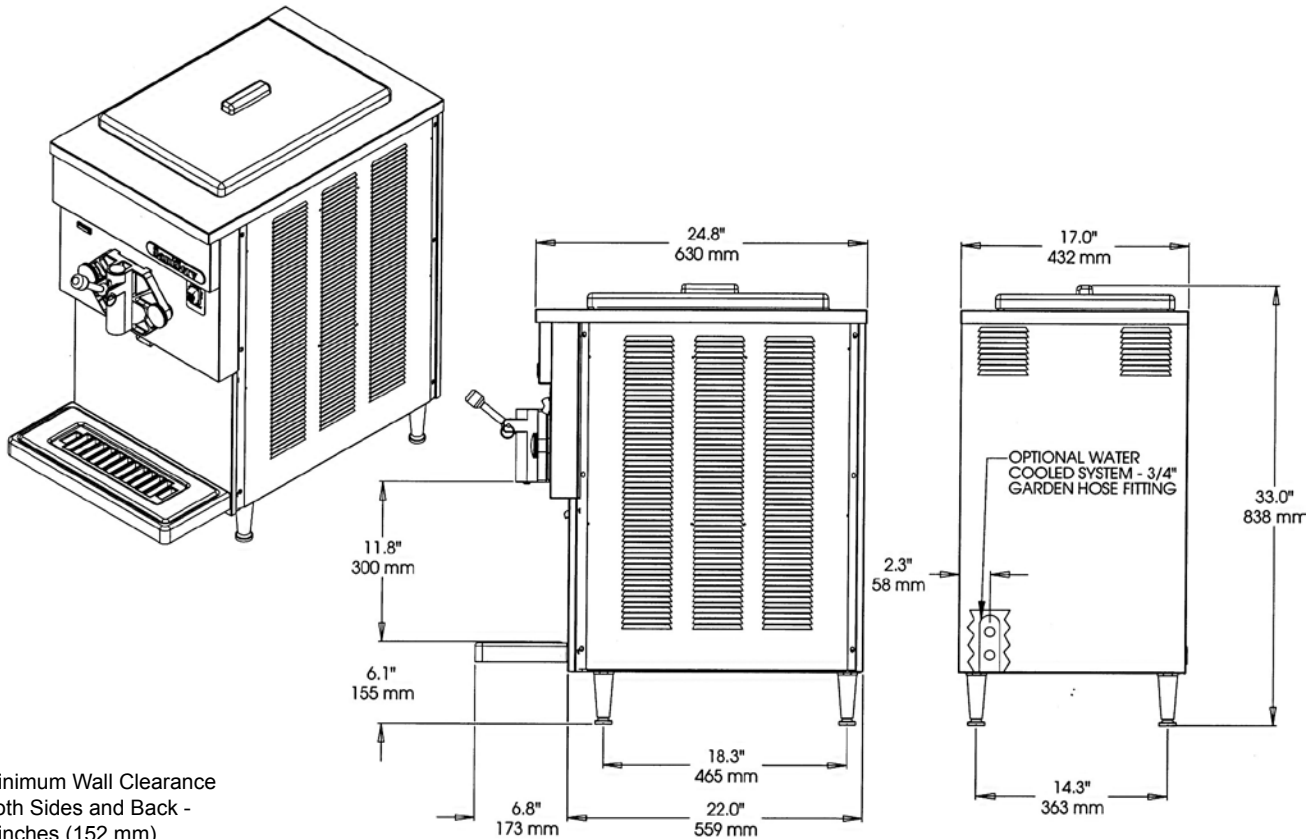

Minimum Wall Clearance
Both Sides and Back -
6 inches (152 mm)

ELECTRICAL				WIDTH	HEIGHT	DEPTH	WEIGHT	VOLUME
VOLTS	Hz	Ph.	Amps	INCHES (MM)	INCHES (MM)	INCHES (MM)	LBS. (Kg)	CU FT. (cu. m.)
115	60	1	15	17 (432)	33 (838)	24.8 (630)	200 (72)	
Shipping Specifications				22.5 (572)	41 (1042)	34.5 (876)	230 (86)	18.5 (.53)

Specifications:

Cooling System:
Air or Water

Dasher and Compressor Motors:

1/4 HP Dasher
3/4 HP Compressor

Refrigerant Type:

R404A

Listings:

UL, NSF

Features:

Evaporator and Mix Reservoir
Capacity:
20 Quarts (18.9 liters)

Dasher:

Heavy-Duty Stainless Steel with low friction scraper blades.

Controls:

AccuFreeze solid-state control for accurate product consistency.

Solid State Audio/Visual Mix Out System with Compressor Lockout

Warranty:

Parts 1 year
Compressor 5 years
Evaporator 5 years

Options:

Parts Tray
Drink Spinner
Syrup Rail
Counter Top Mounting Pad Machine Stand
Wash Out Kit – 3/8" Flare Fitting
Water Cooled – 3/4" Garden Hose Fitting
Export Voltage



DESIGNED FOR MEDIUM VOLUME APPLICATIONS

8 Gallons per Hour – 25 Quart Capacity

HIGH FROZEN PRODUCT VISIBILITY MEANS HIGH PROFITS!

The **SaniServ** model 108 Frozen Beverage Freezer provides owners and operators everything they are asking for: Frozen beverage visibility merchandising in a consistent and reliable machine! The 108's extra large 8 inch face plate design allows customers to view colorful frozen beverages being offered without the condensation and unreliable operation of traditional "bubble top" machines! The high frozen product visibility, along with increased production and reliability, results in increased sales and high profits!

SPACE SAVING

Small Footprint Design - SaniServ model 108 offers frozen product visibility in reliable space saving equipment and design! Owners and Operators can turn the countertop into a highly colorful profit center by providing the frozen beverages customers enjoy!

EASY CLEANING AND OPERATION

Fewer Parts = Simplified Cleaning – SaniServ equipment is designed and built with the fewer parts to be disassembled, cleaned and sanitized than any other machine in the industry.

HIGH RETURN ON INVESTMENT

Increased Profits – SaniServ machines combine affordable efficiency with consistent product quality and fast quiet operation to insure customer satisfaction with high profit frozen beverages.

QUALITY DESIGN

Durability – SaniServ machines are built to achieve long and dependable life through simplicity of design. Every machine is shipped standard with a stainless steel exterior, durable steel interior frame construction, heavy-duty components and consistency systems.

Model 108

Countertop
Frozen Beverage Machine



Made in USA

We reserve the right to change specifications and products design without notice. Such revisions do not entitle the buyer to corresponding changes, improvements, additions or replacements for previously purchased equipment

MODEL 108

Counter Model Frozen Beverage/Cocktail Freezer

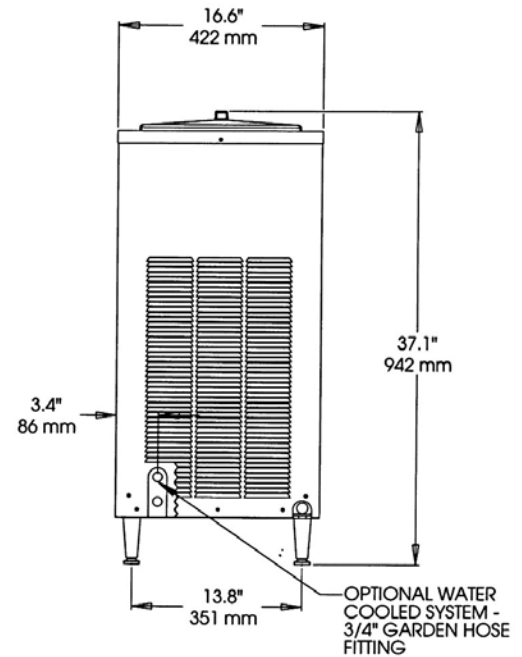
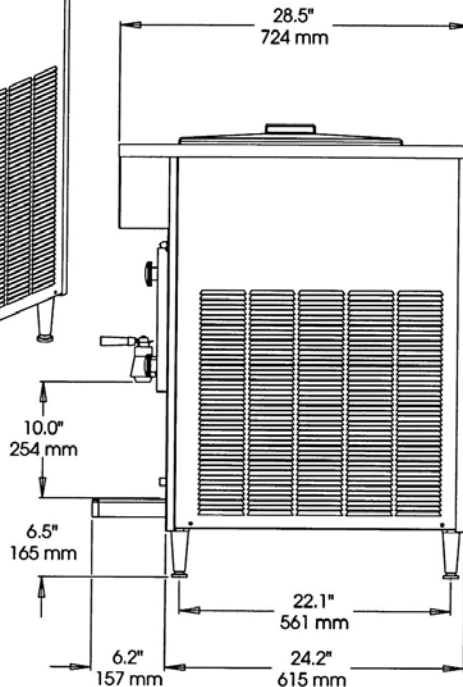
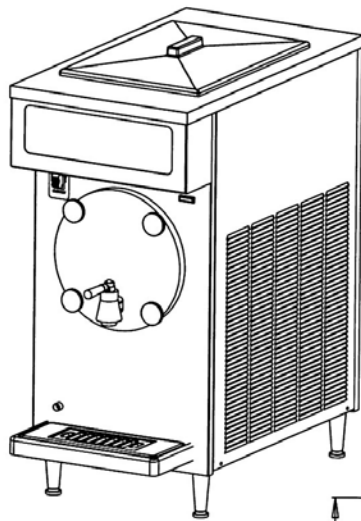

Minimum Wall Clearance
Both Sides and Back -
6 inches (152 mm)

ELECTRICAL				WIDTH	HEIGHT	DEPTH	WEIGHT	VOLUME
VOLTS	Hz	Ph.	Amps	INCHES (MM)	INCHES (MM)	INCHES (MM)	LBS. (Kg)	CU FT. (cu. m.)
115	60	1	15	16.6 (422)	37.1 (942)	28.5 (724)	210 (95)	
Shipping Specifications				22.5 (572)	41 (1042)	34.5 (876)	250 (114)	18.5 (.53)

Specifications:

Cooling System:
Air or Water

Dasher and Compressor Motors:

1/2 HP Dasher
3/4 HP Compressor

Refrigerant Type:

R404A

Listings:

UL, cUL, NSF

Features:

Evaporator and Mix Reservoir
Capacity:
25 Quarts (23.6 liters)

Dasher:

Heavy-Duty Stainless Steel with low friction scraper blades.

Controls:

Automatic consistency controls for improved product consistency.

Solid State Audio/Visual Mix Out System

Warranty:

Parts 1 year
Compressor 5 years
Evaporator 5 years

Options:

Tune Up Kit
Parts Tray
Drink Spinner
Counter Top Mounting Pad
Machine Stand
Wash Out Kit - 3/8" Flare Fitting
Water Cooled - 3/4" Garden Hose Fitting
Export Voltage



DESIGNED FOR MEDIUM VOLUME APPLICATIONS

13 Gallons per Hour – 20 Quart Capacity

SUPER PRODUCTION IN A SMALL DESIGN!

The **SaniServ** model 709 Frozen Beverage Freezer is perfect for providing a high volume of frozen drinks for even the busiest of locations. The increased production makes the model 709 great for providing pitchers of frozen product and supplying plenty of product for larger frozen beverages. With the 709's quick recovery, owners and operators are assured product availability even during peak serving periods!

SPACE SAVING

Small Footprint Design - SaniServ model 709 offers increased production without having to come in a larger design! Owners and Operators can still save valuable floor space and turn the countertop into a high profit center by providing the frozen beverages customers enjoy!

EASY CLEANING AND OPERATION

Fewer Parts = Simplified Cleaning – SaniServ equipment designed and built with the fewer parts to be disassembled, cleaned and sanitized than any other machine in the industry. The state of the art solid-state **AccuFreeze** control insures product consistency, worry-free operation and customer satisfaction.

HIGH RETURN ON INVESTMENT

Increased Profits – SaniServ machines combine affordable efficiency with consistent product quality and fast quiet operation to insure customer satisfaction with high profit frozen beverages.

QUALITY DESIGN

Durability – SaniServ machines are built to achieve long and dependable life through simplicity of design. Every machine is shipped standard with a stainless steel exterior, durable steel interior frame construction, heavy-duty components and consistency systems.

Model 709

Countertop

**Frozen Beverage Machine
With AccuFreeze Control**



Made in USA

We reserve the right to change specifications and products design without notice. Such revisions do not entitle the buyer to corresponding changes, improvements, additions or replacements for previously purchased equipment

MODEL 709

Counter Model Frozen Beverage/Cocktail Freezer

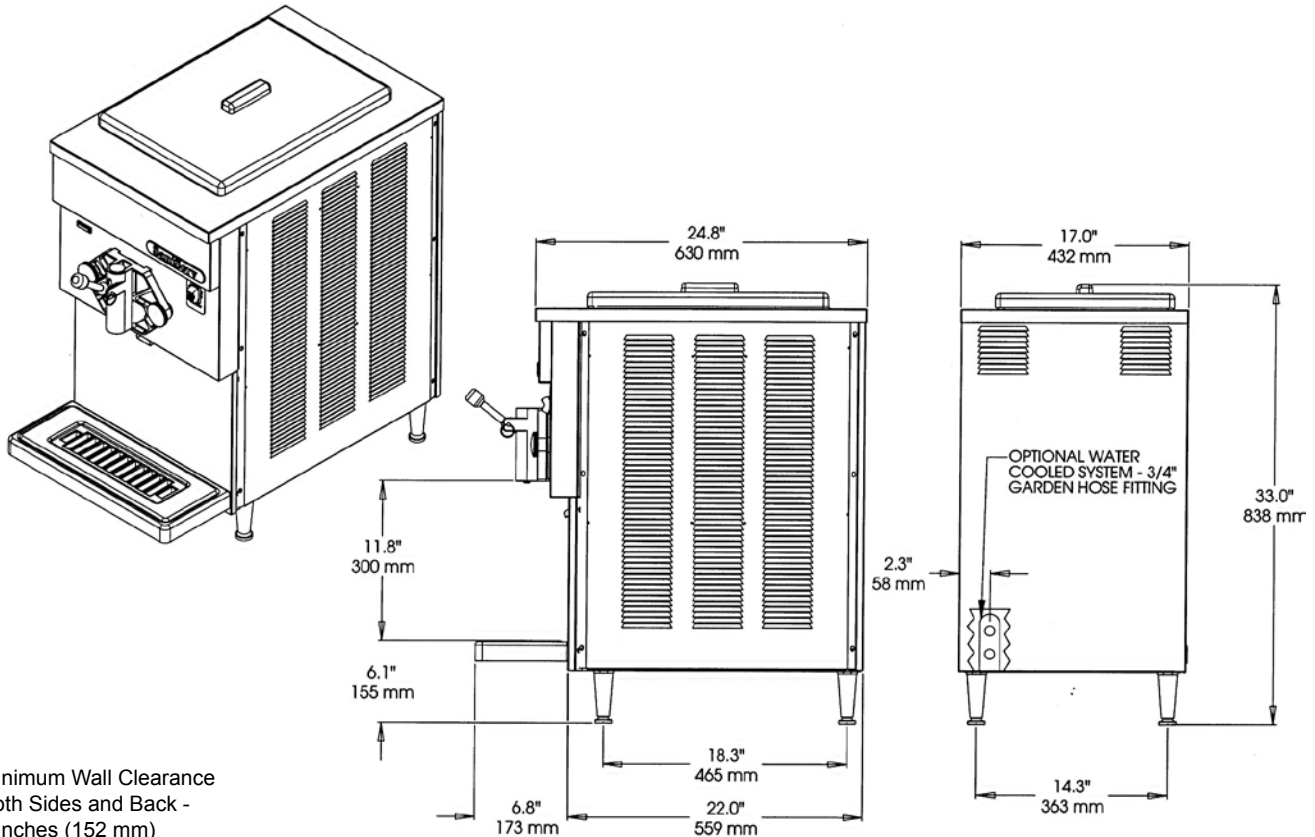

Minimum Wall Clearance
Both Sides and Back -
6 inches (152 mm)

ELECTRICAL				WIDTH	HEIGHT	DEPTH	WEIGHT	VOLUME
VOLTS	Hz	Ph.	Amps	INCHES (MM)	INCHES (MM)	INCHES (MM)	LBS. (Kg)	CU FT. (cu. m.)
208-230	60	1	20	17 (432)	33 (838)	24.8 (630)	207 (94)	
208-230	60	3	15					
Shipping Specifications				22.5 (572)	41 (1042)	34.5 (876)	240 (109)	18.5 (.53)

Specifications:

Cooling System:

Air or Water

Dasher and Compressor Motors:

1/4 HP Dasher
1 HP Compressor

Refrigerant Type:

R404A

Listings:

UL, cUL, NSF

Features:

Evaporator and Mix Reservoir

Capacity:
20 Quarts (18.9 liters)

Dasher:

Heavy-Duty Stainless Steel with low friction scraper blades.

Controls:

AccuFreeze solid-state control for accurate product consistency.

Solid State Audio/Visual Mix Out System with Compressor Lockout

Warranty:

Parts 1 year
Compressor 5 years
Evaporator 5 years

Options:

Tune Up Kit
Parts Tray
Drink Spinner
Lightbox
Counter Top Mounting Pad Machine Stand
Wash Out Kit – 3/8" Flare Fitting
Water Cooled – 3/4" Garden Hose Fitting
Export Voltage



DESIGNED FOR THE HIGHEST VOLUME APPLICATIONS 28 Gallons per Hour – 35 Quart Capacity

A FROZEN BEVERAGE INDUSTRY LEADER!

The **SaniServ** model 704 Frozen Beverage Freezer is perfect for providing a high volume of frozen drinks for the busiest applications and operating hours! The 704 has the highest production capability in the frozen beverage industry! With its quick product freezing and recovery time, along with heavy-duty design, large capacity freezing barrel and product reservoir, the 704 can provide perfect frozen drinks every time!

SPACE SAVING

Small Footprint Design - SaniServ model 704 provides super high production while saving valuable floor space by utilizing the countertop design. With the 704, there is no need to purchase a floor model type machine to attain high production capacity and capability.

EASY CLEANING AND OPERATION

Fewer Parts = Simplified Cleaning – SaniServ equipment is designed and built with the fewer parts to be disassembled, cleaned and sanitized than any other machine in the industry. The state of the art solid-state **AccuFreeze** control insures product consistency, worry-free operation and customer satisfaction.

HIGH RETURN ON INVESTMENT

Increased Profits – SaniServ machines combine affordable efficiency with consistent product quality and fast quiet operation to insure customer satisfaction with high profit frozen beverages.

QUALITY DESIGN

Durability – SaniServ machines are built to achieve long and dependable life through simplicity of design. Every machine is shipped standard with a stainless steel exterior, durable steel interior frame construction, heavy-duty components and consistency systems.

Model 704

Counter Model

**Frozen Beverage Machine
With AccuFreeze Control**



Made in USA

We reserve the right to change specifications and products design without notice. Such revisions do not entitle the buyer to corresponding changes, improvements, additions or replacements for previously purchased equipment

MODEL 704

Counter Model Frozen Beverage/Cocktail Freezer

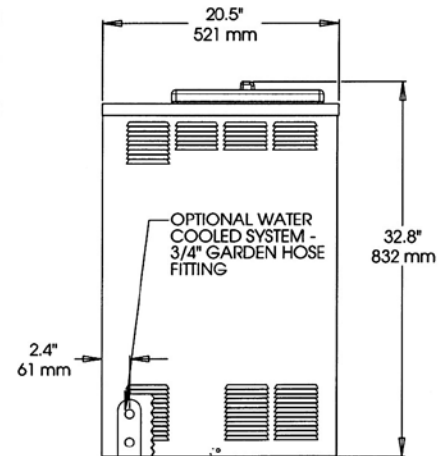
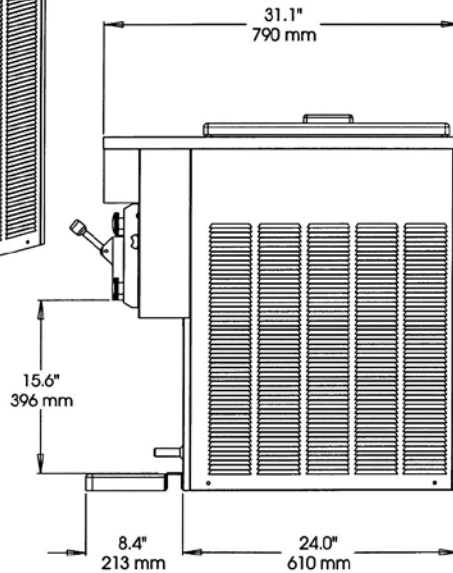
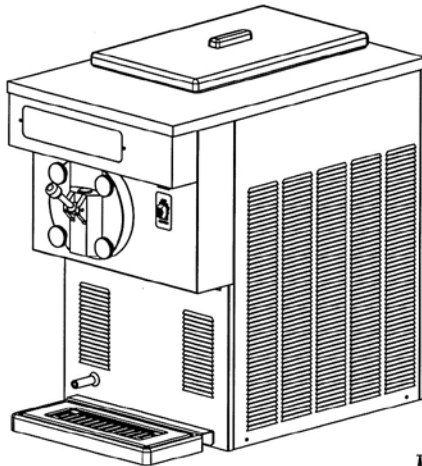

Minimum Wall Clearance
Both Sides and Back -
6 inches (152 mm)

ELECTRICAL				WIDTH	HEIGHT	DEPTH	WEIGHT	VOLUME
VOLTS	Hz	Ph.	Amps	INCHES (MM)	INCHES (MM)	INCHES (MM)	LBS. (Kg)	CU FT. (cu. m.)
208-230	60	1	25	20.5 (521)	32.8 (832)	31.1 (790)	310 (141)	
208-230	60	3	20					
Shipping Specifications				31.5 (800)	40.5 (1029)	40.5 (1029)	350 (159)	29.9 (.84)

Specifications:

Cooling System:

Air or Water

Dasher and Compressor Motors:

1/2 HP Dasher
2 HP Compressor

Refrigerant Type:

R404A

Listings:

UL, cUL, NSF

Features:

Evaporator and Mix Reservoir

Capacity:
35 Quarts (33 liters)

Dasher:

Heavy-Duty Stainless Steel with low friction scraper blades.

Controls:

AccuFreeze solid-state control for accurate product consistency.

Solid State Audio/Visual Mix Out System with Compressor Lockout

Includes Counter Top Mounting Pad

Warranty:

Parts 1 year
Compressor 5 years
Evaporator 5 years

Options:

Tune Up Kit Parts Tray
Auto-fill Lid Drink Spinner
Machine Stand Counter Legs
Water Cooled - 3/4" Garden Hose Fitting
Export Voltage
Remote Condenser*

* Requires a remote condensing unit (condenser & compressor) connected by two refrigeration lines.



DESIGNED FOR MEDIUM VOLUME APPLICATIONS

10 Gal per Hour & 14 Qt Capacity per side

OFFER TWO DIFFERENT FLAVORS IN ONE MACHINE!

The **SaniServ** model 791 Countertop Frozen Beverage Freezer can provide two frozen beverage favorites in one machine! With an independent drive system in each side of the machine, product can be easily maintained and or changed in either side when desired! The mix pan is also refrigerated to ensure quicker recovery time. By offering not one, but two frozen products, owners and operators will insure every customer stays satisfied and increase their operating profits!

SPACE SAVING

Small Footprint Design - SaniServ model 791 provides two frozen beverage flavors in a countertop model design. Operators will enjoy the ease of operation and the versatility to offer two different types of frozen beverages that customers desire at the same time!

EASY CLEANING AND OPERATION

Fewer Parts = Simplified Cleaning – SaniServ equipment is designed and built with the fewer parts to be disassembled, cleaned and sanitized than any other machine in the industry. The state of the art solid-state **AccuFreeze** control insures product consistency, worry-free operation and customer satisfaction.

HIGH RETURN ON INVESTMENT

Increased Profits – SaniServ machines combine affordable efficiency with consistent product quality and fast quiet operation to insure customer satisfaction with high profit frozen beverages.

QUALITY DESIGN

Durability – SaniServ machines are built to achieve long and dependable life through simplicity of design. Every machine is shipped standard with a stainless steel exterior, durable steel interior frame construction, heavy-duty components and consistency systems.

Model 791

Twin Flavor Counter
Frozen Beverage Machine
With **AccuFreeze** Control



Made in USA

We reserve the right to change specifications and products design without notice. Such revisions do not entitle the buyer to corresponding changes, improvements, additions or replacements for previously purchased equipment

MODEL 791

Counter Model Frozen Beverage/Cocktail Freezer

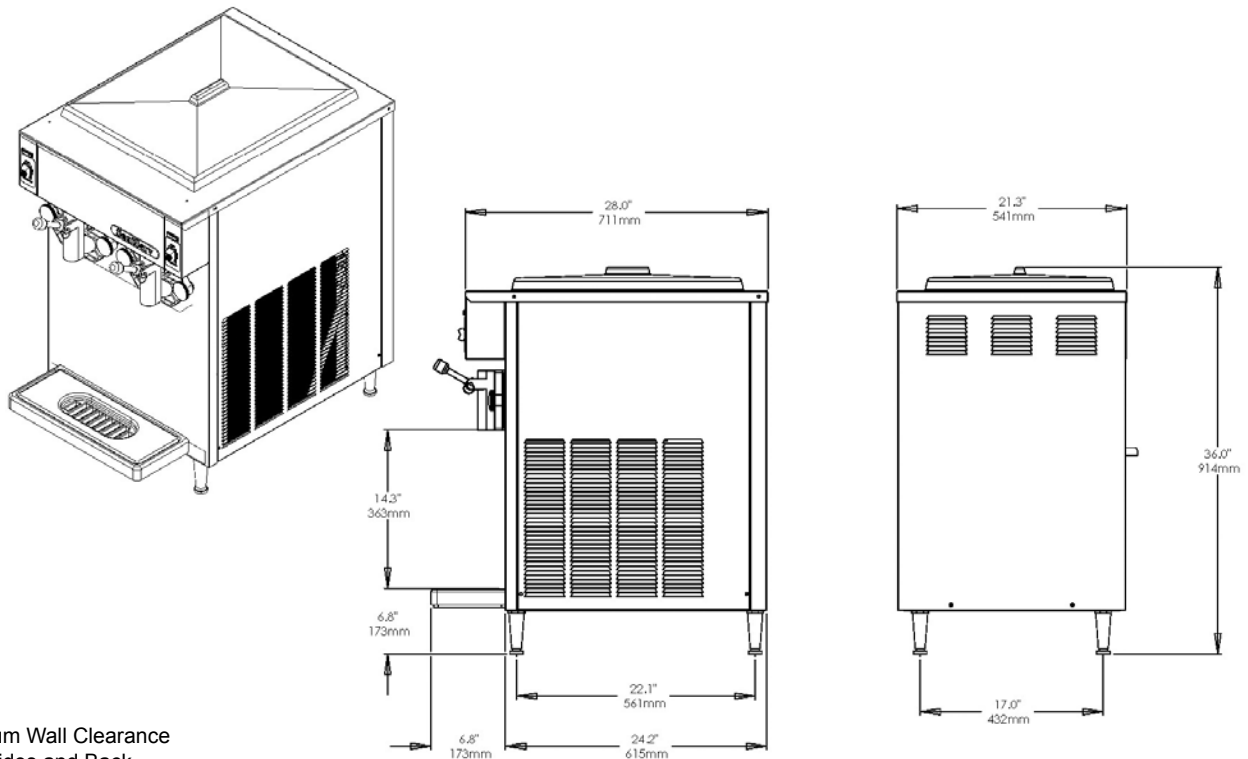

Minimum Wall Clearance
Both Sides and Back -
6 inches (152 mm)

ELECTRICAL				WIDTH	HEIGHT	DEPTH	WEIGHT	VOLUME
VOLTS	Hz	Ph.	Amps	INCHES (MM)	INCHES (MM)	INCHES (MM)	LBS. (Kg)	CU FT. (cu. m.)
208-230	60	1	20	21.3 (541)	36 (914)	28 (711)	249 (118)	
208-230	60	3	15					
Shipping Specifications				31.5 (800)	36.5 (927)	40.5 (1029)	330 (150)	29.6 (.83)

Specifications:

Cooling System:
Air Only

Dasher and Compressor Motors:

(2) 1/4 HP Dashers
(1) 1 HP Compressor

Refrigerant Type:
R404A

Listings:
UL, NSF

Features:

Evaporator and Mix Reservoir Capacity:
14 Quarts (13.2 liters) per side

Dasher:

Heavy-Duty Stainless Steel with low friction scraper blades.

Controls:

AccuFreeze solid-state control for accurate product consistency.

Solid State Audio/Visual Mix Out System with Compressor Lockout

Warranty:

Parts 1 year
Compressor 5 years
Evaporator 5 years

Options:

Tune Up Kit Parts Tray
Drink Spinner Syrup Rail
Auto-fill Machine Stand
Export Voltage
Remote Condenser*

* Requires a remote condensing unit (condenser & compressor) connected by two refrigeration lines.



DESIGNED FOR MEDIUM VOLUME APPLICATIONS

6 Gal per Hour & 14 Qt Capacity per side

OFFER TWO DIFFERENT FLAVORS IN ONE MACHINE!

The **SaniServ** model 798 Countertop Frozen Beverage Freezer can provide two frozen beverage favorites in one machine! With an independent drive system in each side of the machine, product can be easily maintained and or changed in either side when desired! The 798's mix pan is also refrigerated to ensure quicker recovery time. By offering not one, but two frozen products, owners and operators will insure every customer stays satisfied and increase their operating profits!

SPACE SAVING

Small Footprint Design - SaniServ model 798 provides two frozen beverage flavors in a counter-top model design. Operators will enjoy the ease of operation and the versatility to offer two different types of frozen beverages that customers desire at the same time!

EASY CLEANING AND OPERATION

Fewer Parts = Simplified Cleaning – SaniServ equipment is designed and built with the fewer parts to be disassembled, cleaned and sanitized than any other machine in the industry. The state of the art solid-state **AccuFreeze** control insures product consistency, worry-free operation and customer satisfaction.

HIGH RETURN ON INVESTMENT

Increased Profits – SaniServ machines combine affordable efficiency with consistent product quality and fast quiet operation to insure customer satisfaction with high profit frozen beverages.

QUALITY DESIGN

Durability – SaniServ machines are built to achieve long and dependable life through simplicity of design. Every machine is shipped standard with a stainless steel exterior, durable steel interior frame construction, heavy-duty components and consistency systems.

Model 798

Twin Flavor Counter Model Freezer
Frozen Beverage Machine
With **AccuFreeze** Control



Made in USA

We reserve the right to change specifications and products design without notice. Such revisions do not entitle the buyer to corresponding changes, improvements, additions or replacements for previously purchased equipment

MODEL 798

Counter Model Frozen Beverage/Cocktail Freezer

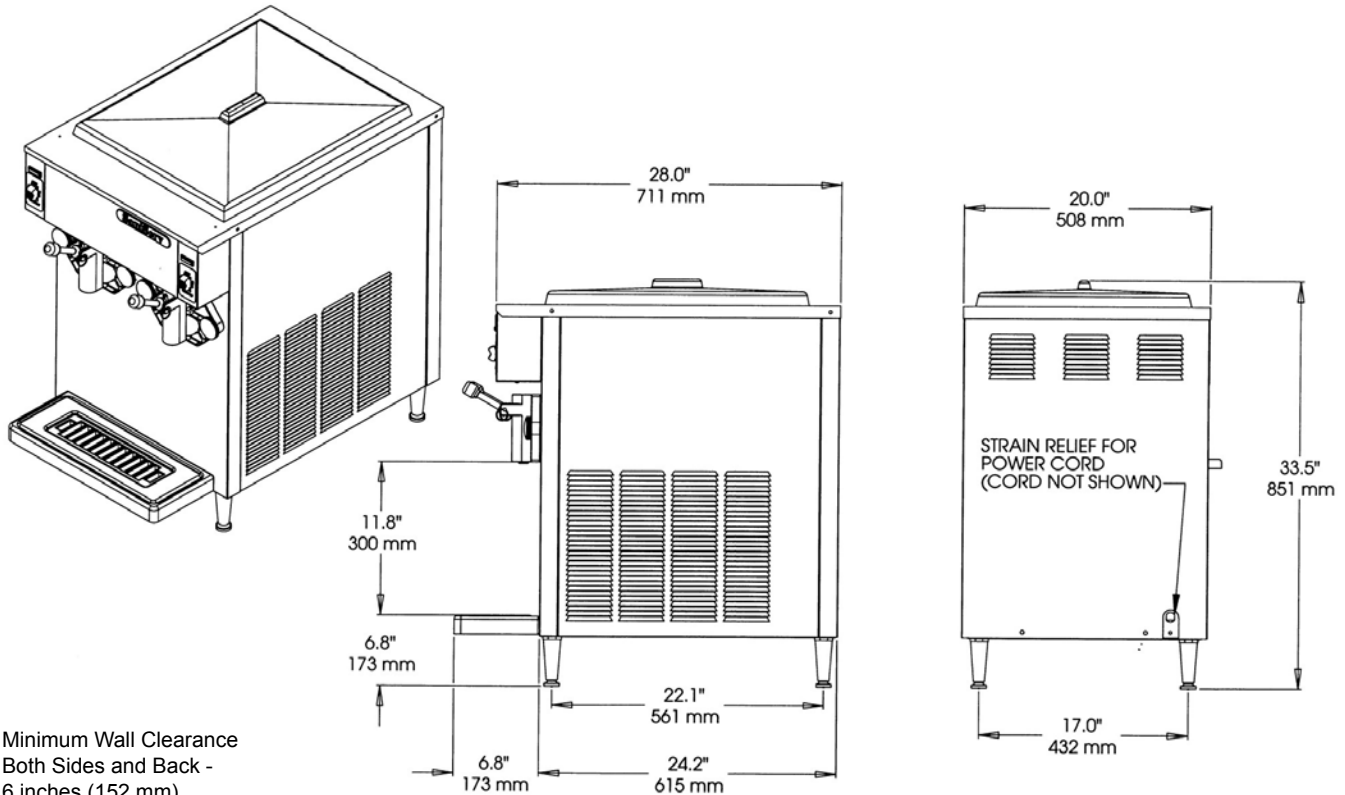

Minimum Wall Clearance
Both Sides and Back -
6 inches (152 mm)

ELECTRICAL				WIDTH	HEIGHT	DEPTH	WEIGHT	VOLUME
VOLTS	Hz	Ph.	Amps	INCHES (MM)	INCHES (MM)	INCHES (MM)	LBS. (Kg)	CU FT. (cu. m.)
115	60	1	15	20 (508)	33.5 (851)	28 (711)	234 (106)	
Shipping Specifications				31.5 (800)	40.5 (1029)	40.5 (1029)	315 (143)	29.9 (.84)

Specifications:

Cooling System:

Air Only

Dasher and Compressor Motors:

(2) 1/4 HP Dashers
(1) 3/4 HP Compressor

Refrigerant Type:

R404A

Listings:

UL, NSF

Features:

Evaporator and Mix Reservoir

Capacity:

14 Quarts (13.2 liters) per side

Dasher:

Heavy-Duty Stainless Steel with low friction scraper blades.

Controls:

AccuFreeze solid-state control for accurate product consistency.

Solid State Audio/Visual Mix Out System with Compressor Lockout

Warranty:

Parts 1 year
Compressor 5 years
Evaporator 5 years

Options:

Tune Up Kit Parts Tray
Drink Spinner Syrup Rail
Auto-fill Machine Stand
Water Cooled – 3/4" Garden Hose Fitting
Export Voltage
Remote Condenser*

* Requires a remote condensing unit (condenser & compressor) connected by two refrigeration lines.



DESIGNED FOR HIGH VOLUME APPLICATIONS

20 Gal per Hour - 20 Quart Capacity

HIGH PRODUCTION IN A TRADITIONAL FLOOR MODEL DESIGN!

The **SaniServ** model 714 Floor Model Frozen Beverage Freezer provides high production frozen beverages even in the busiest of applications! With its sleek single barrel profile and traditional floor model design, the 714 has the ability to offer many types of slush beverages. Choose from frozen margaritas and daiquiris to frozen fruit flavor drinks such as frozen lemonade and fruit smoothies!

SPACE SAVING

Compact Floor Model Design - SaniServ model 714 provides a high volume dispenser in a compact, traditional floor model design. Operators will enjoy the ease of operation and the ability to utilize the 714's versatility to provide the different types of frozen beverages that customers want!

EASY CLEANING AND OPERATION

Fewer Parts = Simplified Cleaning – SaniServ equipment is designed and built with the fewer parts to be disassembled, cleaned and sanitized than any other machine in the industry. The state of the art solid-state **AccuFreeze** control insures product consistency, worry-free operation and customer satisfaction.

HIGH RETURN ON INVESTMENT

Increased Profits – SaniServ machines combine affordable efficiency with consistent product quality and fast quiet operation to insure customer satisfaction with high profit frozen beverages.

QUALITY DESIGN

Durability – SaniServ machines are built to achieve long and dependable life through simplicity of design. Every machine is shipped standard with a stainless steel exterior, durable steel interior frame construction, heavy-duty components and consistency systems.

Model 714

Floor Model

**Frozen Beverage Machine
With AccuFreeze Control**



Made in USA

We reserve the right to change specifications and products design without notice. Such revisions do not entitle the buyer to corresponding changes, improvements, additions or replacements for previously purchased equipment



MODEL 714

Floor Model Frozen Beverage/Cocktail Freezer

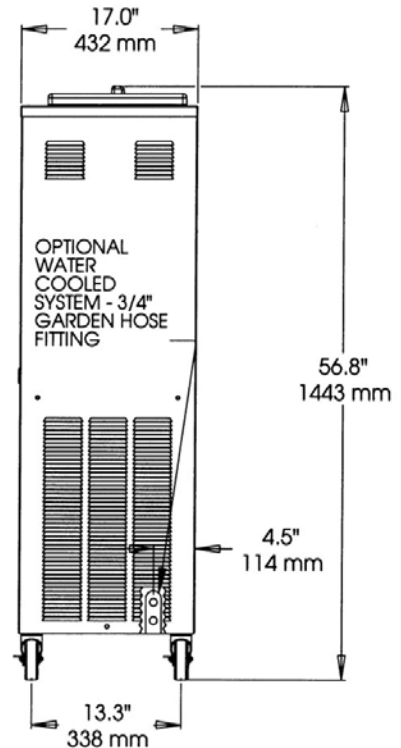
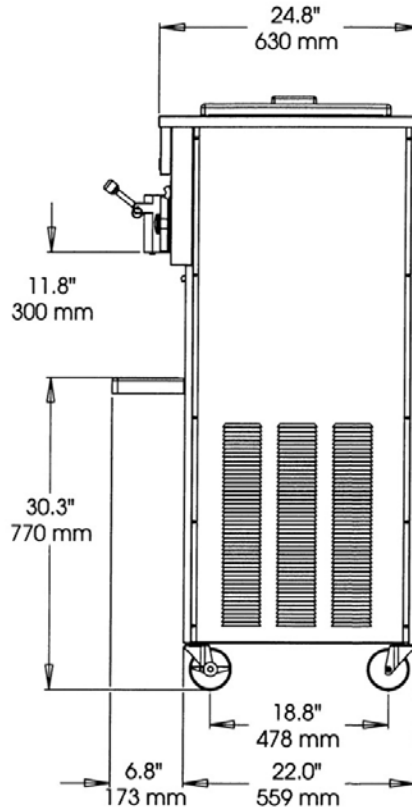
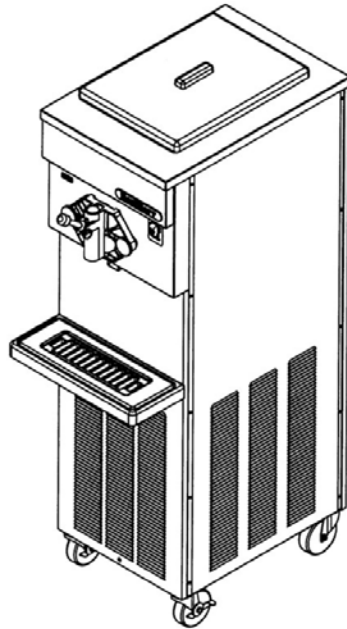

Minimum Wall Clearance
Both Sides and Back -
6 inches (152 mm)

ELECTRICAL				WIDTH	HEIGHT	DEPTH	WEIGHT	VOLUME
VOLTS	Hz	Ph.	Amps	INCHES (MM)	INCHES (MM)	INCHES (MM)	LBS. (Kg)	CU FT. (cu. m.)
208-230	60	1	25	17 (432)	56.8 (1443)	24.8 (630)	305 (139)	
208-230	60	3	20					
Shipping Specifications				24.5 (622)	58.1 (1476)	40.5 (1029)	345 (157)	32.4 (.91)

Specifications:

Cooling System:

Air or Water

Dasher and Compressor Motors:

1/4 HP Dasher
2 HP Compressor

Refrigerant Type:

R404A

Listings:

UL, cUL, NSF

Features:

Evaporator and Mix Reservoir

Capacity:
20 Quarts (18.9 liters)

Dasher:

Heavy-Duty Stainless Steel with low friction scraper blades.

Controls:

AccuFreeze solid-state control for accurate product consistency.

Solid State Audio/Visual Mix Out System with Compressor Lockout

Warranty:

Parts 1 year
Compressor 5 years
Evaporator 5 years

Options:

Tune Up Kit
Parts Tray
Drink Spinner
Syrup Rail
Wash Out Kit - 3/8" Flare Fitting
Water Cooled - 3/4" Garden Hose Fitting
Export Voltage



DESIGNED FOR HIGH VOLUME APPLICATIONS

20 Gal per Hour - 20 Quart Capacity - Per Side

HIGH PRODUCTION AND TWO FLAVORS IN A FLOOR MODEL DESIGN

The **SaniServ** model 724 Floor Model Frozen Beverage Freezer provides not one but two frozen beverage flavors in a high production floor model machine! The output and versatility of the 724 means owners and operators can offer two frozen best sellers. Because each side of the machine utilizes its own 2 HP refrigeration system, customers are always insured of getting their favorites!

HEAVY DUTY

Floor Model Design - SaniServ model 724 provides a high volume of frozen beverages in the traditional floor model design. Operators will enjoy the ease of operation and the ability to utilize the 724's versatility to provide the different types of frozen beverages that customers want!

EASY CLEANING AND OPERATION

Fewer Parts = Simplified Cleaning – SaniServ equipment is designed and built with the fewer parts to be disassembled, cleaned and sanitized than any other machine in the industry. The state of the art solid-state **AccuFreeze** control insures product consistency, worry-free operation and customer satisfaction.

HIGH RETURN ON INVESTMENT

Increased Profits – SaniServ machines combine affordable efficiency with consistent product quality and fast quiet operation to insure customer satisfaction with high profit frozen beverages.

QUALITY DESIGN

Durability – SaniServ machines are built to achieve long and dependable life through simplicity of design. Every machine is shipped standard with a stainless steel exterior, durable steel interior frame construction, heavy-duty components and consistency systems.

Model 724

Floor Model

Twin Flavor

**Frozen Beverage Machine
With AccuFreeze Control**



Made in USA

We reserve the right to change specifications and products design without notice. Such revisions do not entitle the buyer to corresponding changes, improvements, additions or replacements for previously purchased equipment

MODEL 724

Floor Model Twin Head Frozen Beverage Freezer

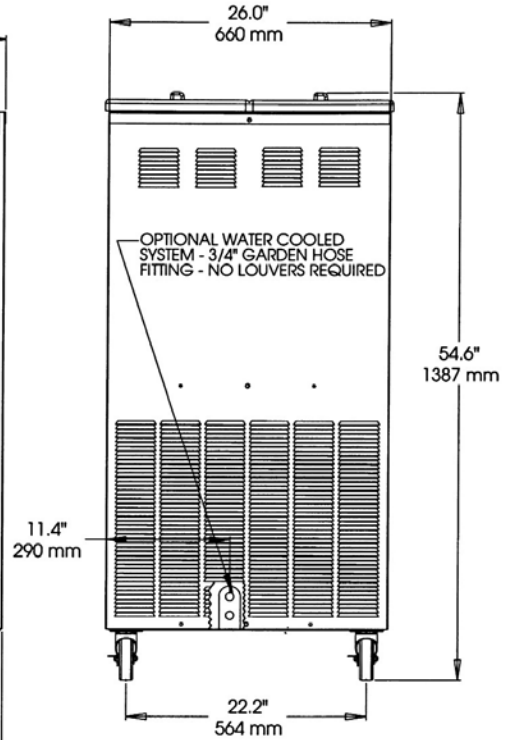
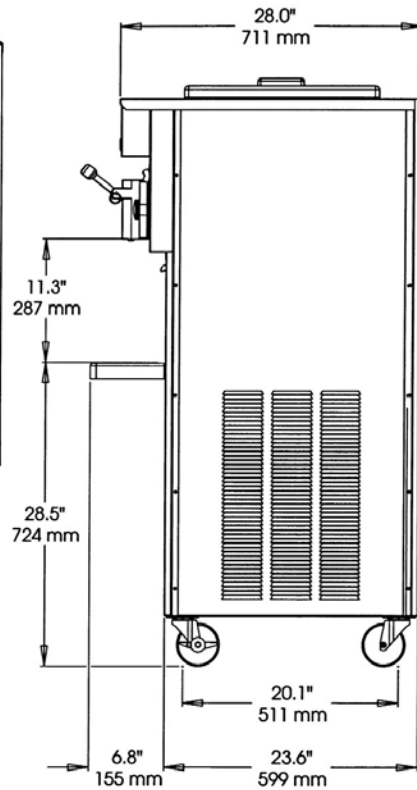
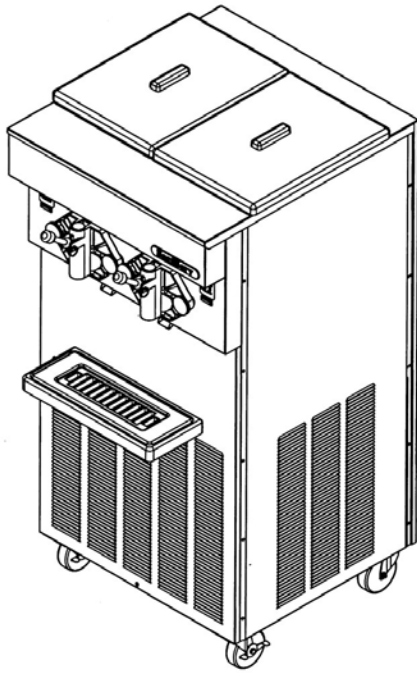

Minimum Wall Clearance
Both Sides and Back -
6 inches (152 mm)

Specifications:

Cooling System:
Air or Water

Dasher and Compressor Motors:

(2) 1/4 HP Dasher
(2) 2 HP Compressor

Refrigerant Type:
R404A

Features:

Evaporator and Mix Reservoir Capacity:
20 Quarts (18.9 liters) per side

Dasher:
Heavy-Duty Stainless Steel with low friction scraper blades.

Controls:
AccuFreeze solid-state control for accurate product consistency.

Solid State Audio/Visual Mix Out System with Compressor Lockout

Warranty:

Parts	1 year
Compressor	5 years
Evaporator	5 years

Options:

- Tune Up Kit
- Parts Tray
- Drink Spinner
- Syrup Rail
- Wash Out Kit - 3/8" Flare Fitting
- Water Cooled - 3/4" Garden Hose Fitting
- Export Voltage



DESIGNED FOR MEDIUM VOLUME APPLICATIONS

4 Mixed Slushes per Minute – 20 Quart Capacity

FOUR DIFFERENT SLUSH FLAVORS AT THE PRESS OF A BUTTON!

The **SaniServ** model 701SAS Floor Model Frozen Beverage Freezer is perfect for providing a choice of any four different slush flavors in one compact machine! By providing slush in different flavors at the touch of a button, customers will always find the flavors that they want and will keep them coming back for more! The 701SAS automatically mixes each slush uniformly each time to insure perfect frozen drinks in the flavor desired! Three blended flavors mean no mixing and measuring. Everyone gets their favorite!

SPACE SAVING

Compact Design - **SaniServ** model 701SAS provides four flavors in one machine in a compact countertop design. Operators will enjoy the ease of operation and utilize the 701's ability to turn counter space into a high profit center by providing four flavors of frozen beverage and providing a flavor that every customer enjoys!

EASY CLEANING AND OPERATION

Fewer Parts = Simplified Cleaning – **SaniServ** equipment is designed and built with the fewer parts to be disassembled, cleaned and sanitized than any other machine in the industry.

HIGH RETURN ON INVESTMENT

Increased Profits – **SaniServ** machines combine affordable efficiency with consistent product quality and fast quiet operation to insure customer satisfaction with high profit frozen beverages.

QUALITY DESIGN

Durability – **SaniServ** machines are built to achieve long and dependable life through simplicity of design. Every machine is shipped standard with a stainless steel exterior, durable steel interior frame construction, heavy-duty components and consistency systems.

Model 701SAS

Floor Model
Slush Plus

Frozen Beverage Machine



Made in USA

We reserve the right to change specifications and products design without notice. Such revisions do not entitle the buyer to corresponding changes, improvements, additions or replacements for previously purchased equipment



DESIGNED FOR HIGH VOLUME APPLICATIONS

6 Mixed Slushes per Minute – 20 Quart Capacity

FOUR DIFFERENT SLUSH FLAVORS AT THE PRESS OF A BUTTON!

The **SaniServ** model 714SAS Floor Model Frozen Beverage Freezer is perfect for providing a choice of any four different slush flavors in one compact machine! By providing slush in different flavors at the touch of a button, customers will always find the flavors that they want and will keep them coming back for more! The 714SAS automatically mixes each slush uniformly each time to insure perfect frozen drinks in the flavor desired! Three blended flavors mean no mixing and measuring; everyone gets their favorite!

SPACE SAVING

Compact Floor Model Design - SaniServ model 714SAS provides four flavors in one machine in a traditional floor model design. Operators will enjoy the ease of operation and utilize the 714's ability to turn floor space into a high profit center by providing four flavors of frozen beverage and providing a flavor that every customer enjoys!

EASY CLEANING AND OPERATION

Fewer Parts = Simplified Cleaning – SaniServ equipment is designed and built with the fewer parts to be disassembled, cleaned and sanitized than any other machine in the industry.

HIGH RETURN ON INVESTMENT

Increased Profits – SaniServ machines combine affordable efficiency with consistent product quality and fast quiet operation to insure customer satisfaction with high profit frozen beverages.

QUALITY DESIGN

Durability – SaniServ machines are built to achieve long and dependable life through simplicity of design. Every machine is shipped standard with a stainless steel exterior, durable steel interior frame construction, heavy-duty components and consistency systems.

Model 714SAS

Floor Model
Slush Plus
Frozen Beverage Machine



Made in USA

We reserve the right to change specifications and products design without notice. Such revisions do not entitle the buyer to corresponding changes, improvements, additions or replacements for previously purchased equipment



MODEL 714SAS

Floor Model Frozen Beverage/Cocktail Freezer

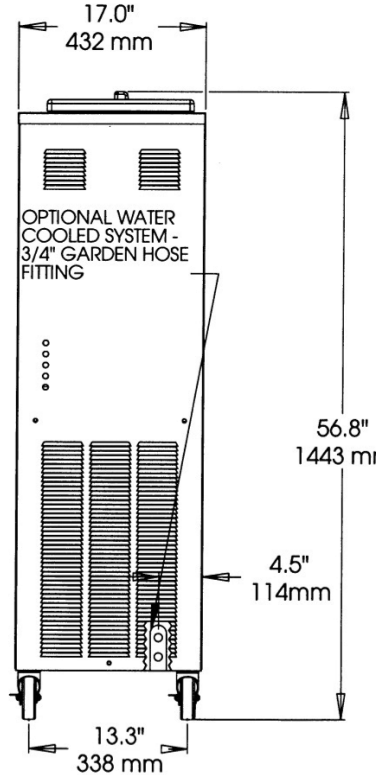
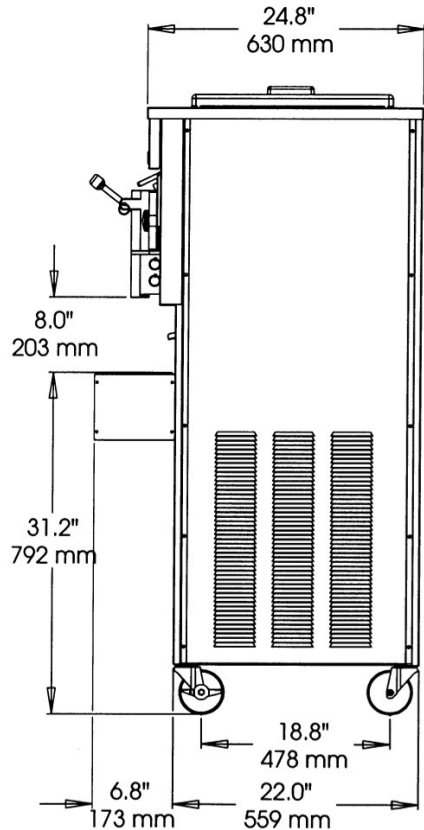
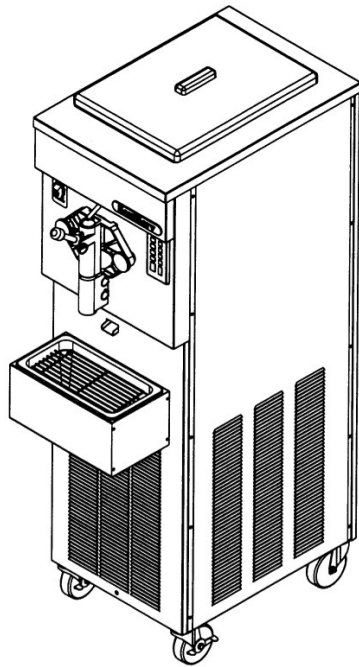

Minimum Wall Clearance
Both Sides and Back -
6 inches (152 mm)

ELECTRICAL				WIDTH	HEIGHT	DEPTH	WEIGHT	VOLUME
VOLTS	Hz	Ph.	Amps	INCHES (MM)	INCHES (MM)	INCHES (MM)	LBS. (Kg)	CU FT. (cu. m.)
208-230	60	1	25	17(432)	56.8 (1443)	24.8 (630)	342 (156)	
208-230	60	3	20					
Shipping Specifications				24.5 (622)	58.1 (1476)	40.5 (1029)	382 (174)	32.5 (.92)

Specifications:

Cooling System:
Air or Water

Dasher and Compressor Motors:

1/2 HP Dasher
2 HP Compressor

Refrigerant Type:

R404A

Listings:

UL, cUL, NSF

Features:

Evaporator and Mix Reservoir Capacity:
20 Quarts (18.9 liters)

Dasher:

Heavy-Duty Stainless Steel with low friction scraper blades.

Controls:

Automatic consistency controls for improved product consistency.

Solid-state Automatic Audio and Visual Mix Out Alert System

Warranty:

Parts 1 year
Compressor 5 years
Evaporator 5 years

Options:

Tune Up Kit
Parts Tray
Wash Out Kit - 3/8" Flare Fitting
Water Cooled -3/4" Garden Hose Fitting
Export Voltage



DESIGNED FOR HIGH VOLUME APPLICATIONS

5 Quart Capacity

Ideal for Pool side, Beach Bars, Conventions, Catering and Special Events

Open up new markets with the **SaniServ** 708PBS Frozen Beverage Freezer! The unique model 708PBS allows business owners to serve highly profitable alcoholic and non-alcoholic product lines. Utilizing keg canisters means no mixing or measuring liquid product. By combining easy to serve, consistent product and an innovative design, the 708PBS is sure to be a crowd favorite!

NO MIXING OR MEASURING

Simply install keg canisters in refrigerated base with product from local wholesaler, connect CO2 line and serve perfect consistent frozen drinks every time.

FAST SERVICE

Just pull the spigot handle to dispense the product. No wasted time pouring, measuring or blending drinks. No hauling ice or cleaning blender cups.

EASY CLEANING AND OPERATION

Fewer Parts = Simplified Cleaning – SaniServ SaniServe equipment is designed and built with the fewer parts to be disassembled, cleaned and sanitized than any other machine in the industry.

HIGH RETURN ON INVESTMENT

Increased Profits – SaniServ machines combine affordable efficiency with consistent product quality and fast quiet operation to insure customer satisfaction with high profit frozen beverages.

DURABILITY

Durability – SaniServ machines are built to achieve long and dependable life through simplicity of design. Every machine is shipped standard with a stainless steel exterior, durable steel interior frame construction, heavy-duty components and consistency systems.

Model 708PBS

Pressurized

Frozen Beverage Machine
with Refrigerated Base



Made in USA

We reserve the right to change specifications and products design without notice. Such revisions do not entitle the buyer to corresponding changes, improvements, additions or replacements for previously purchased equipment

MODEL 708PBS

Pressurized Frozen Beverage System for Keg

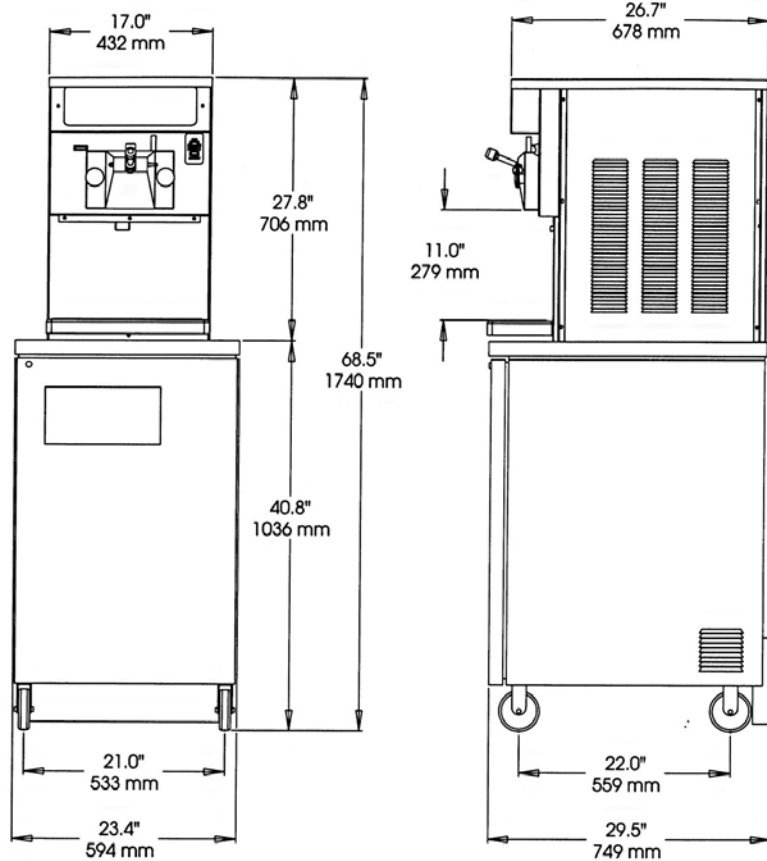
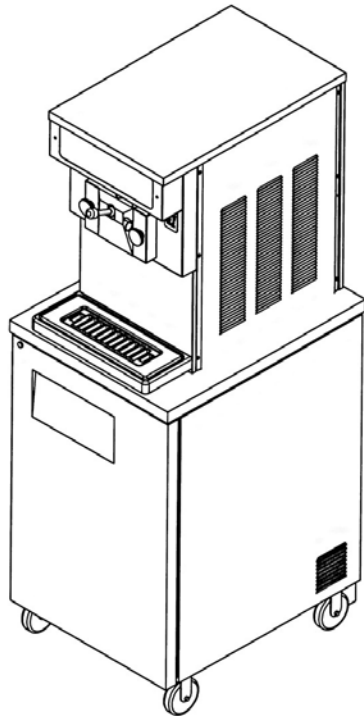

Minimum Wall Clearance
Both Sides and Back -
6 inches (152 mm)

ELECTRICAL				WIDTH	HEIGHT	DEPTH	WEIGHT	VOLUME
VOLTS	Hz	Ph.	Amps	INCHES (MM)	INCHES (MM)	INCHES (MM)	LBS. (Kg)	CU FT. (cu. m.)
115	60	1	15	23.4 (594)	68.5 (1740)	29.5 (749)	370 (168)	
115	60	1	2x15					
Shipping Specifications				31.5 (800)	79 (2006)	37 (940)	497 (225)	38(1.1)

Specifications:

Cooling System:
Air or Water

Dasher and Compressor Motors:

1/2 HP Dasher
3/4 HP Compressor
1/5 HP Cabinet Compressor

Refrigerant Type:

Machine: R404A
Cabinet: R134A

Features:

Evaporator and Mix Reservoir
Capacity:
5 Quarts (4.7 liters)

Dasher:

Heavy-Duty Stainless Steel with low friction scraper blades.

Controls:

Automatic consistency controls for improved product consistency.

Solid-state Automatic Visual Mix Out Alert System

Warranty:

Parts 1 year
Compressor 5 years
Evaporator 5 years

Options:

Tune Up Kit
Parts Tray
Shipping Crate



DESIGNED FOR HIGH VOLUME APPLICATIONS

16 Gallons per Hour – 25 Quart Capacity

HIGH FROZEN PRODUCT VISIBILITY MEANS HIGH PROFITS!

The **SaniServ** model 108R Frozen Beverage Freezer provides owners and operators everything they are asking for: *Frozen beverage visibility merchandising* in a consistent and reliable machine with *remote refrigeration* and *remote auto fill!* The unit's extra large 8" faceplate design allows customers to view colorful frozen beverages being offered without the condensation and unreliable operation of traditional "bubble top" machines! The high frozen product visibility, along with increased production and reliability, results in increased sales and high profits! The 108R's remote refrigeration system is ideal for lowering costly indoor air conditioning operating costs by providing less heat build up while providing quieter operation!

SPACE SAVING

Small Footprint Design - SaniServ model 108R offers frozen product visibility in reliable space saving equipment and design! Owners and Operators can turn the countertop into a highly colorful profit center by providing the frozen beverages customers enjoy!

EASY CLEANING AND OPERATION

Fewer Parts = Simplified Cleaning – SaniServ equipment is designed and built with the fewer parts to be disassembled, cleaned and sanitized than any other machine in the industry.

HIGH RETURN ON INVESTMENT

Increased Profits – SaniServ machines combine affordable efficiency with consistent product quality and fast quiet operation to insure customer satisfaction with high profit frozen beverages.

QUALITY DESIGN

Durability – SaniServ machines are built to achieve long and dependable life through simplicity of design. Every machine is shipped standard with a stainless steel exterior, durable steel interior frame construction, heavy-duty components and consistency systems.

Model 108R

Countertop
Frozen Beverage Machine
Remote Fill & Remote Condenser



Made in USA

We reserve the right to change specifications and products design without notice. Such revisions do not entitle the buyer to corresponding changes, improvements, additions or replacements for previously purchased equipment

MODEL 108R

Counter Frozen Beverage Freezer w/Remote Condenser

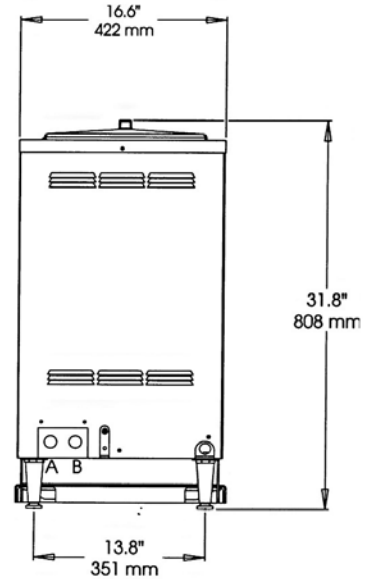
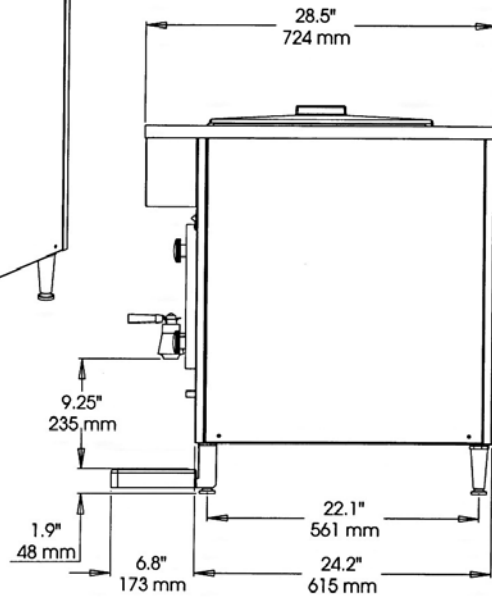
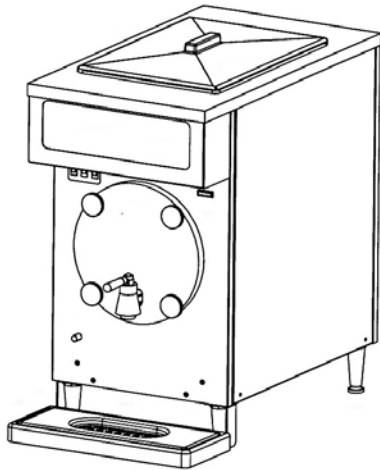

Minimum Wall Clearance
Both Sides and Back -
6 inches (152 mm)

A 5/8" SUCTION LINE QUICK DISCONNECT
B 3/8" LIQUID LINE QUICK DISCONNECT

ELECTRICAL				WIDTH	HEIGHT	DEPTH	WEIGHT	VOLUME
VOLTS	Hz	Ph.	Amps	INCHES (MM)	INCHES (MM)	INCHES (MM)	LBS. (Kg)	CU FT. (cu. m.)
115	60	1	15	16.6 (422)	31.8 (808)	28.5 (724)	150 (69)	
Shipping Specifications				22.5 (572)	36.5 (965)	36.5 (927)	185 (85)	18 (.51)

Specifications:

Cooling System:
Remote Required

Dasher Motor:
1/2 HP

Refrigerant Type:
R404A

Listings:
NSF

Features:

Evaporator and Mix Reservoir
Capacity:
25 Quarts (23.6 liters)

Dasher:
Heavy-Duty Stainless Steel with low friction scraper blades.

Controls:
Automatic consistency controls for improved product consistency.

Solid-state Automatic Visual Mix Out Alert System

Warranty:

Parts 1 year
Evaporator 5 years

Options:

Tune Up Kit
Parts Tray
Drink Spinner
Machine Stand
Export Voltage
Wash Out Kit – 3/8" Flare Fitting
Remote Condenser*

* Requires a remote condensing unit (condenser & compressor) connected by two refrigeration lines.



DESIGNED FOR MEDIUM VOLUME APPLICATIONS

10 Gal per Hour & 14 Qt Capacity per side

OFFER TWO DIFFERENT FLAVORS IN ONE MACHINE!

The **SaniServ** model 798R Countertop Frozen Beverage Freezer can provide two frozen beverage favorites in one machine! With an independent drive system in each side of the machine, product can be easily maintained and or changed in either side when desired! The 798R's mix pan is also refrigerated to ensure quicker recovery time. By offering not one, but two frozen products, owners and operators will insure every customer stays satisfied and increase their operating profits! The 798R's remote refrigeration system is ideal for lowering costly indoor air conditioning operating costs by providing less heat build up while providing quieter operation!

SPACE SAVING

Small Footprint Design - SaniServ model 798 provides two frozen beverage flavors in a countertop model design. Operators will enjoy the ease of operation and the versatility to offer two different types of frozen beverages that customers desire at the same time!

EASY CLEANING AND OPERATION

Fewer Parts = Simplified Cleaning – SaniServ equipment is designed and built with the fewer parts to be disassembled, cleaned and sanitized than any other machine in the industry. The state of the art solid-state **AccuFreeze** control insures product consistency, worry-free operation and customer satisfaction.

HIGH RETURN ON INVESTMENT

Increased Profits – SaniServ machines combine affordable efficiency with consistent product quality and fast quiet operation to insure customer satisfaction with high profit frozen beverages.

QUALITY DESIGN

Durability – SaniServ machines are built to achieve long and dependable life through simplicity of design. Every machine is shipped standard with a stainless steel exterior, durable steel interior frame construction, heavy-duty components and consistency systems.

Model 798R

**Twin Flavor Counter Model Freezer
Frozen Beverage Machine
Remote Condensing
With AccuFreeze Control**



Made in USA

We reserve the right to change specifications and products design without notice. Such revisions do not entitle the buyer to corresponding changes, improvements, additions or replacements for previously purchased equipment

MODEL 798R

Counter Model Frozen Beverage/Cocktail Freezer Remote Condensing

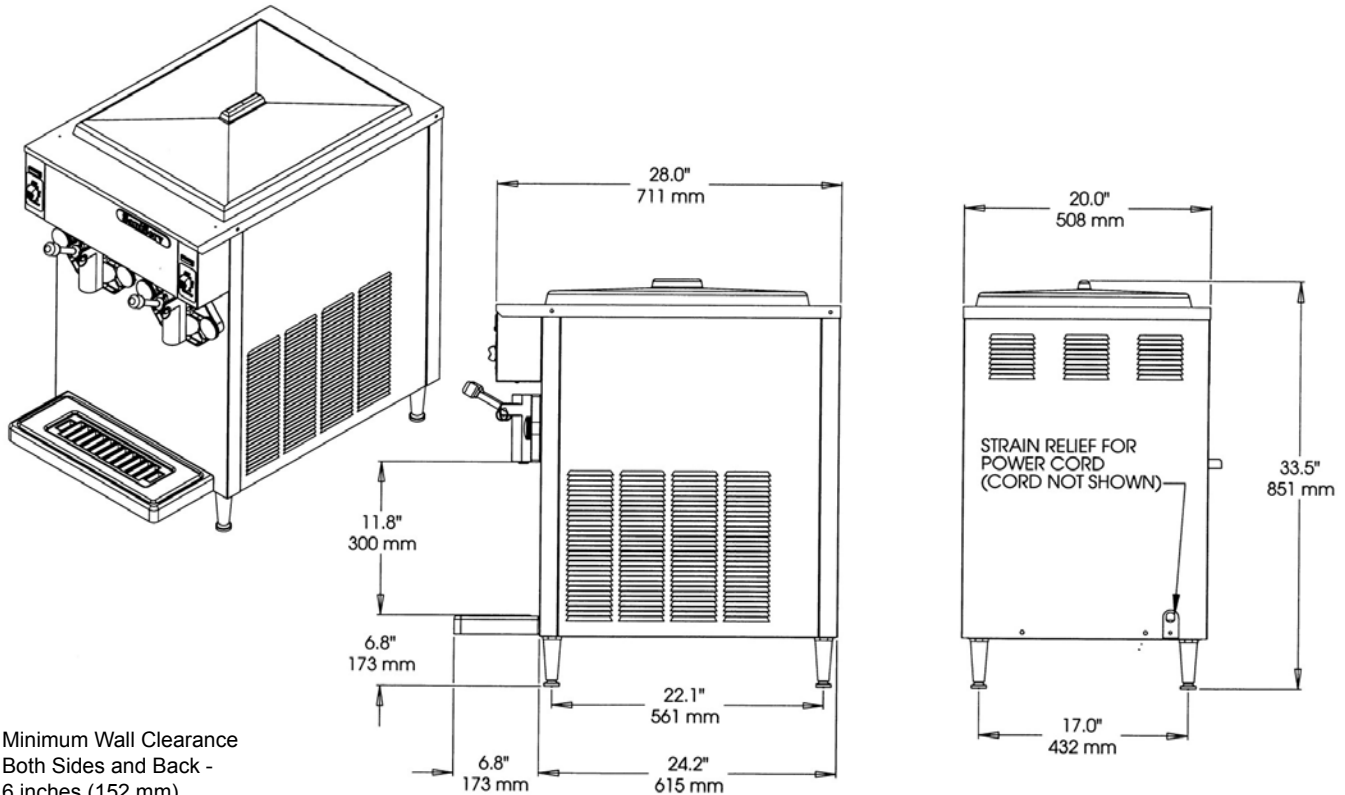

Minimum Wall Clearance
Both Sides and Back -
6 inches (152 mm)

ELECTRICAL				WIDTH	HEIGHT	DEPTH	WEIGHT	VOLUME
VOLTS	Hz	Ph.	Amps	INCHES (MM)	INCHES (MM)	INCHES (MM)	LBS. (Kg)	CU FT. (cu. m.)
115	60	1	15	20 (508)	33.5 (851)	28 (711)	185 (85)	
Shipping Specifications				31.3 (800)	36.5 (927)	40.5 (1029)	265 (121)	29.6 (.83)

Specifications:

Cooling System:
Remote Required

Dasher and Compressor Motors:
(2) 1/4 HP Dashers

Refrigerant Type:
R404A

Listings:
UL, NSF

Required Additional Equipment:
Remote Condenser and compressor

Features:

Evaporator and Mix Reservoir Capacity:
14 Quarts (13.2 liters)

Dasher:
Heavy-Duty Stainless Steel with low friction scraper blades.

Controls:
AccuFreeze solid-state control for accurate product consistency.

Solid State Audio/Visual Mix Out System with Compressor Lockout

Warranty:

Parts 1 year
Evaporator 5 years

Options:

Tune Up Kit Parts Tray
Drink Spinner Syrup Rail
Auto-fill Machine Stand



DESIGNED FOR HIGH VOLUME APPLICATIONS

20 Gallons per Hour – 5 Quart Evaporator Capacity

AUTO-FILL SYSTEM FOR CONTINUOUS PRODUCT SUPPLY!

The **SaniServ** model WB700 Remote Refrigeration Auto-Fill Frozen Beverage Freezer is designed to provide a high volume of frozen beverages through a continuous product source such as; “bag in the box” or pre-mixed product supply systems! The WB700 remote refrigeration system is ideal for lowering costly indoor air conditioning operating costs by providing less heat build up while providing quieter operation! The space saving design of the WB700 is a perfect solution to provide countertops with frozen beverages!

SUPER SPACE SAVING

Small Footprint Design - SaniServ model WB700 offers frozen beverages in the smallest space saving equipment and design available! Owners and Operators can turn even the smallest of countertop space into a high profit center while enjoying lower indoor operating costs and providing the frozen beverages customers want!

EASY CLEANING AND OPERATION

Fewer Parts = Simplified Cleaning – SaniServ equipment is designed and built with the fewer parts to be disassembled, cleaned and sanitized than any other machine in the industry. The state of the art solid-state **AccuFreeze** control insures product consistency, worry-free operation and customer satisfaction.

HIGH RETURN ON INVESTMENT

Increased Profits – SaniServ machines combine affordable efficiency with consistent product quality and fast quiet operation to insure customer satisfaction with high profit frozen beverages.

QUALITY DESIGN

Durability – SaniServ machines are built to achieve long and dependable life through simplicity of design. Every machine is shipped standard with a stainless steel exterior, durable steel interior frame construction, heavy-duty components and consistency systems.

Model WB700

Countertop
**Remote Refrigeration
Frozen Beverage Machine
With AccuFreeze Control**



Made in USA

We reserve the right to change specifications and products design without notice. Such revisions do not entitle the buyer to corresponding changes, improvements, additions or replacements for previously purchased equipment

MODEL WB700

Counter Model Frozen Beverage Freezer w/Remote Condenser & Remote Fill

These units may interface with existing beer and wine transfer systems by the addition of an additional regulator to further reduce the pressure of the normal system.

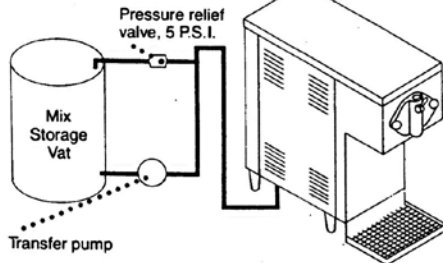

Note: This unit requires remote refrigeration system, not shown.

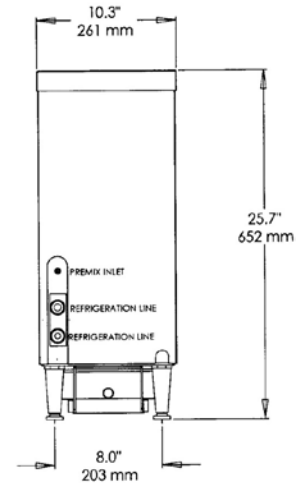
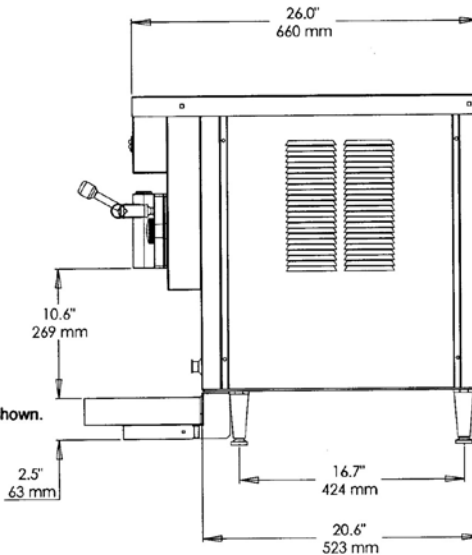

Minimum Wall Clearance
Both Sides and Back -
6 inches (152 mm)

ELECTRICAL				WIDTH	HEIGHT	DEPTH	WEIGHT	VOLUME
VOLTS	Hz	Ph.	Amps	INCHES (MM)	INCHES (MM)	INCHES (MM)	LBS. (Kg)	CU FT. (cu. m.)
115	60	1	15	10.3 (261)	25.7 (652)	26.0 (660)	105 (48)	
Shipping Specifications				22.5 (572)	36.5 (965)	36.5 (927)	135 (61)	18 (.51)

Specifications:

Cooling System:
Remote Required

Dasher Motor:
1/4 HP

Refrigerant Type:
R404A

Listings:
UL, cUL, NSF

Required additional equipment:
Remote Condenser and Compressor

Pre-mixed Product Delivery System

Features:

Evaporator and Mix Reservoir Capacity:
5 Quarts (4.7 liters)

Dasher:
Heavy-Duty Stainless Steel with low friction scraper blades.

Controls:
AccuFreeze solid-state control for accurate product consistency.

Solid State Audio/Visual Mix Out System with Compressor Lockout

Warranty:

Parts 1 year
Compressor Not provided

Options:

Tune Up Kit
Parts Tray
Drink Spinner
Machine Stand
Export Voltage



DESIGNED FOR HIGH VOLUME APPLICATIONS
20 Gallons per Hour – 5 Quart Evaporator Capacity - per side

AUTO-FILL SYSTEM FOR CONTINUOUS PRODUCT SUPPLY!

The **SaniServ** model WB700-2 Twin Head Frozen Beverage Freezer, with Remote Refrigeration and Auto-Fill, is designed to provide a high volume of frozen beverages through a continuous product source such as “bag in the box” or pre-mixed product supply systems. The WB700’s remote refrigeration system lowers the cost of indoor air-conditioning and reduces heat and noise levels.

COUNTERTOP CONVENIENCE

The **SaniServ** WB700-2, with Remote Refrigeration and Auto-Fill system, provides **two flavors** of high volume / high profit frozen beverages at the countertop, quietly and without the mess of product filling.

EASY CLEANING AND OPERATION

Fewer Parts = Simplified Cleaning – SaniServ equipment is designed and built with the fewer parts to be disassembled, cleaned and sanitized than any other machine in the industry. The state of the art solid-state **AccuFreeze** control insures product consistency, worry-free operation and customer satisfaction.

HIGH RETURN ON INVESTMENT

Increased Profits – SaniServ machines combine affordable efficiency with consistent product quality and fast quiet operation to insure customer satisfaction with high profit frozen beverages.

QUALITY DESIGN

Durability – SaniServ machines are built to achieve long and dependable life through simplicity of design. Every machine is shipped standard with a stainless steel exterior, durable steel interior frame construction, heavy-duty components and consistency systems.

**Model
WB700-2**

Countertop
**Twin Head - Remote Refrigeration
 Frozen Beverage Machine
 With AccuFreeze Control**



Made in USA

We reserve the right to change specifications and products design without notice. Such revisions do not entitle the buyer to corresponding changes, improvements, additions or replacements for previously purchased equipment



MODEL WB700-2

Counter Model Twin Head Frozen Beverage Freezer w/Remote Condenser & Remote Fill

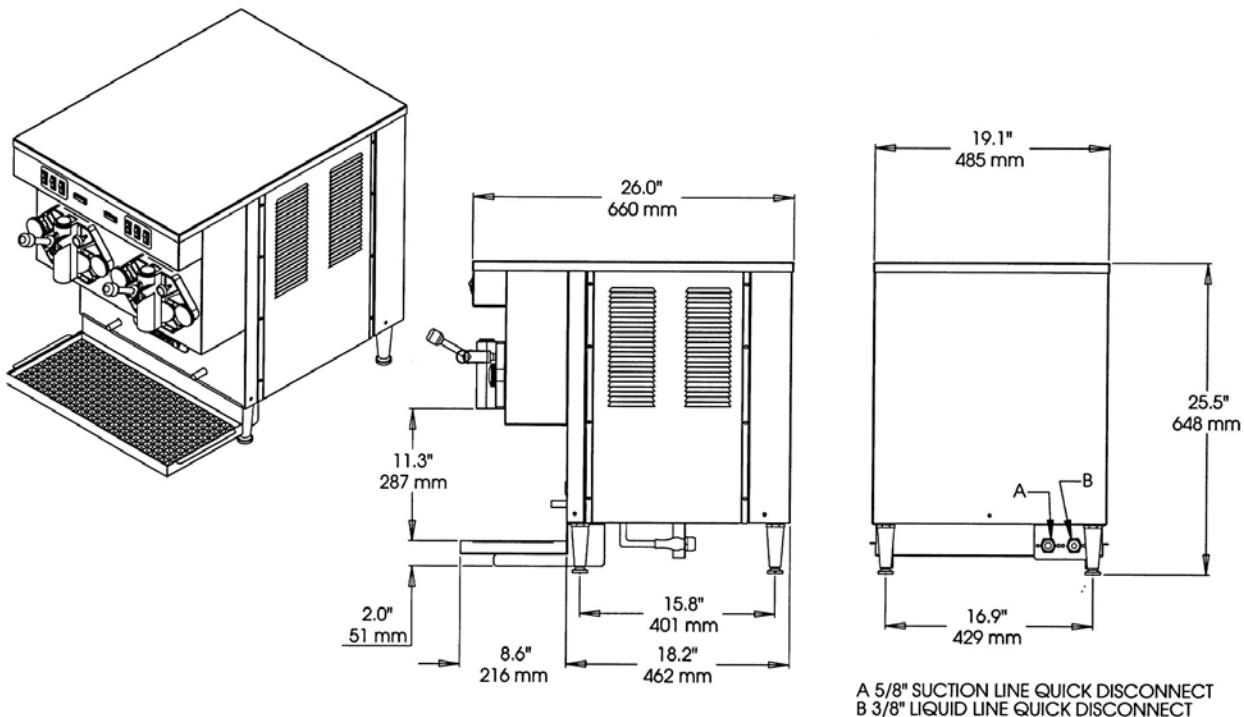

Minimum Wall Clearance
Both Sides and Back -
6 inches (152 mm)

ELECTRICAL				WIDTH	HEIGHT	DEPTH	WEIGHT	VOLUME
VOLTS	Hz	Ph.	Amps	INCHES (MM)	INCHES (MM)	INCHES (MM)	LBS. (Kg)	CU FT. (cu. m.)
115	60	1	15	19.1 (660)	25.5 (648)	26 (660)	185 (85)	
Shipping Specifications				31.3 (800)	36.5 (927)	36.5 (927)	215 (98)	29.6 (.83)

Specifications:

Cooling System:
Remote Required

Dasher Motor:
1/4 HP

Refrigerant Type:
R404A

Listings:
UL, cUL, NSF

Required additional equipment:
Remote Condenser and Compressor

Features:

Evaporator and Mix Reservoir Capacity:
5 Quarts (4.7 liters)

Dasher:
Heavy-Duty Stainless Steel with low friction scraper blades.

Controls:
AccuFreeze solid-state control for accurate product consistency.

Solid State Audio/Visual Mix Out System with Compressor Lockout

Warranty:

Parts 1 year
Compressor Not provided

Options:

Tune Up Kit
Parts Tray
Drink Spinner
Machine Stand
Export Voltage



DESIGNED FOR HIGH VOLUME APPLICATIONS

25 Gallons per Hour – 7 Qt. Evaporator

COMPLETE AUTO-FILL SYSTEM IN A SPACE SAVING DESIGN!

The **SaniServ** model WB7110 Remote Refrigeration Auto-fill Frozen Beverage Freezer is designed to provide a high volume of frozen beverages through a continuous product source such as; “bag in the box” or pre-mixed product supply systems! The WB7110 remote refrigeration system is ideal for lowering costly indoor air conditioning operating costs by providing less heat build up while providing quieter operation! The space saving design of the WB7110 is a perfect solution to provide countertops with frozen beverages!

SPACE SAVING

Small Footprint Design - SaniServ offers frozen beverages in the smallest space saving equipment and design available! Owners and Operators can turn even the smallest of countertop space into a high profit center while enjoying lower indoor operating costs and providing the frozen beverages customers want!

EASY CLEANING AND OPERATION

Fewer Parts = Simplified Cleaning – SaniServ equipment is designed and built with the fewer parts to be disassembled, cleaned and sanitized than any other machine in the industry.

HIGH RETURN ON INVESTMENT

Increased Profits – SaniServ machines combine affordable efficiency with consistent product quality and fast quiet operation to insure customer satisfaction with high profit frozen beverages.

QUALITY DESIGN

Durability – SaniServ machines are built to achieve long and dependable life through simplicity of design. Every machine is shipped standard with a stainless steel exterior, durable steel interior frame construction, heavy-duty components and consistency systems.

Model WB7110

Countertop
Remote System
Frozen Beverage Machine



Made in USA

We reserve the right to change specifications and products design without notice. Such revisions do not entitle the buyer to corresponding changes, improvements, additions or replacements for previously purchased equipment

MODEL WB7110

Frozen Beverage Counter Freezer w/Remote Condenser & Remote Fill

These units may interface with existing beer and wine transfer systems by the addition of an additional regulator to further reduce the pressure of the normal system.

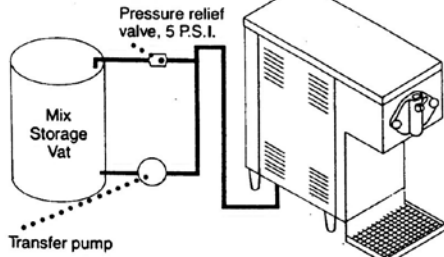

Note: This unit requires remote refrigeration system, not shown.

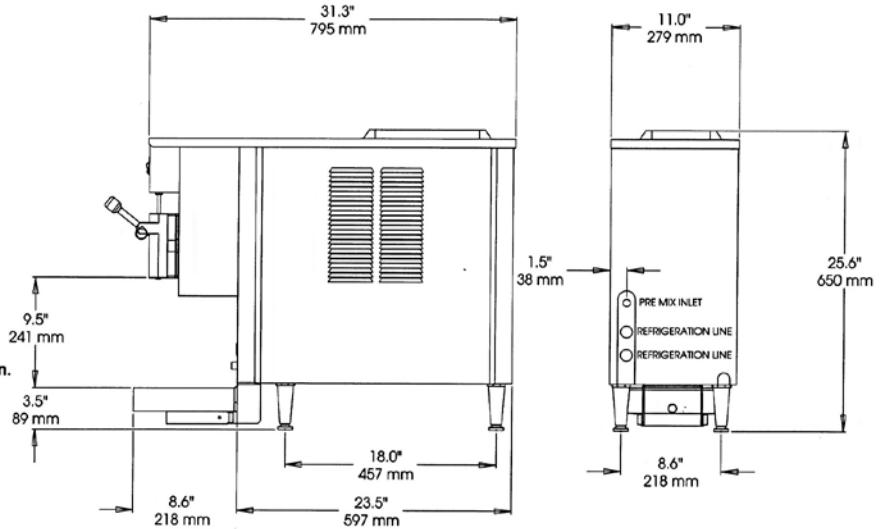

Minimum Wall Clearance
Both Sides and Back -
6 inches (152 mm)

ELECTRICAL				WIDTH	HEIGHT	DEPTH	WEIGHT	VOLUME
VOLTS	Hz	Ph.	Amps	INCHES (MM)	INCHES (MM)	INCHES (MM)	LBS. (Kg)	CU FT. (cu. m.)
115	60	1	15	11 (279)	25.6 (650)	31.3 (795)	124 (56)	
Shipping Specifications				22.5 (572)	38 (965)	36.5 (927)	154 (70)	18 (.51)

Specifications:

Cooling System:
Remote Required

Dasher Motor:
1/4 HP

Refrigerant Type:
R404A

Listings:
UL, cUL, NSF

Required additional equipment:
Remote Condenser and Compressor

Required BTU/Hour:
Max 13,750 at 0 degrees F evaporator and 110 degrees F condensing.

Features:

Evaporator and Mix Reservoir Capacity:
7 Quarts (6.6 liters)

Dasher:
Heavy-Duty Stainless Steel with low friction scraper blades.

Solid-state Automatic Visual Mix Out Alert System

Warranty:

Parts 1 year
Evaporator 5 years

Options:

Tune Up Kit
Parts Tray
Drink Spinner
Machine Stand
Export Voltage
Remote Condenser*

* Requires a remote condensing unit (condenser & compressor) connected by two refrigeration lines.



DESIGNED FOR LOW VOLUME APPLICATIONS

2½ Gallons per Hour – 7 Quart Capacity

ECONOMICAL IN PRICE & SPACE!

The **SaniServ** model DF100 Frozen Beverage Freezer is the perfect addition to establishments wishing to offer their customers premium frozen beverages like margaritas and daiquiris. Economical in price and space, **DuraFreeze** offers the prospect for high profits and customer satisfaction.

SPACE SAVING

Small Footprint Design - SaniServ model DF100 offers frozen beverages in the smallest space saving equipment and design available! Owners and Operators can turn even the smallest of countertop space into a high profit center while enjoying lower indoor operating costs and providing the frozen beverages customers want!

EASY CLEANING AND OPERATION

Fewer Parts = Simplified Cleaning – SaniServ equipment is designed and built with the fewer parts to be disassembled, cleaned and sanitized than any other machine in the industry.

HIGH RETURN ON INVESTMENT

Increased Profits – SaniServ machines combine affordable efficiency with consistent product quality and fast quiet operation to insure customer satisfaction with high profit frozen beverages.

QUALITY DESIGN

Durability – SaniServ machines are built to achieve long and dependable life through simplicity of design. Every machine is shipped standard with a stainless steel exterior, durable construction, heavy-duty components and consistency systems.

Model DF100

Countertop
Frozen Beverage Machine
DuraFreeze



Made in USA

We reserve the right to change specifications and products design without notice. Such revisions do not entitle the buyer to corresponding changes, improvements, additions or replacements for previously purchased equipment

MODEL DF100

Counter Model Frozen Beverage/Cocktail Freezer

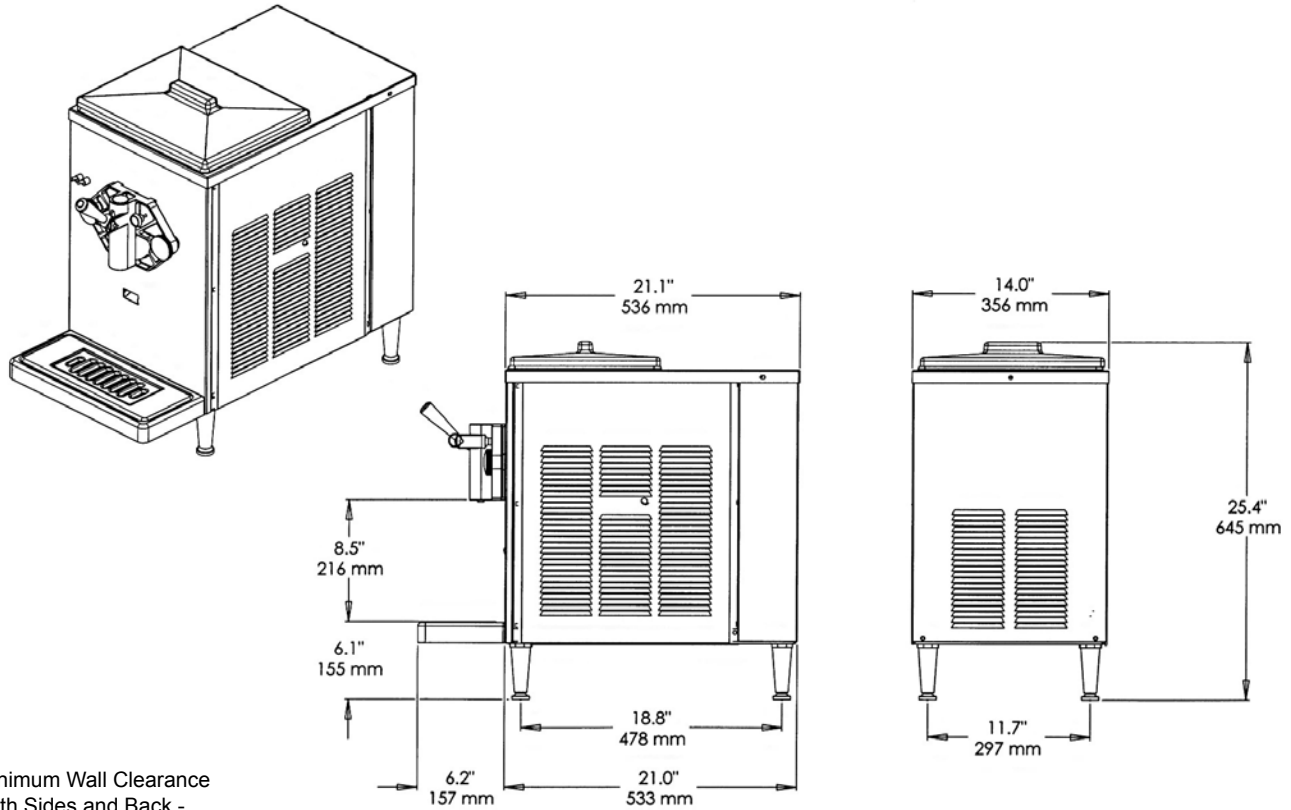

Minimum Wall Clearance
Both Sides and Back -
6 inches (152 mm)

ELECTRICAL				WIDTH	HEIGHT	DEPTH	WEIGHT	VOLUME
VOLTS	Hz	Ph.	Amps	INCHES (MM)	INCHES (MM)	INCHES (MM)	LBS. (Kg)	CU FT. (cu. m.)
115	60	1	15	14 (356)	25.4 (648)	21.1 (536)	145 (66)	
Shipping Specifications				22.5 (572)	31.5 (800)	34 (863)	172 (78)	8.6 (.24)

Specifications:

Cooling System:
Air Only

Dasher and Compressor Motor:
1/4 HP Dasher
1/3 HP Compressor

Refrigerant Type:
R404A

Listings:
UL, cUL, NSF

Features:

Evaporator and Mix Reservoir
Capacity:
7 Quarts (6.6 liters)

Dasher:
Heavy-Duty Stainless Steel with low friction scraper blades.

Controls:
Automatic consistency controls for improved product consistency.

Warranty:

Parts 90 days
Compressor 1 year
Labor 30 days

Options:

Tune Up Kit
Machine Stand
Custom Graphic



DESIGNED FOR LOW VOLUME APPLICATIONS

Two 3 oz. Servings per minute – 7 Qt. Capacity

ECONOMICAL IN PRICE & SPACE!

The **SaniServ** model DF200 Soft Serv/Yogurt Freezer is ideal for providing small servings, samplers, and adding a-la-mode to favorite desserts. Economical in price and space, **DuraFreeze** offers the prospect for high profits and customer satisfaction.

SPACE SAVING

Small Footprint Design - SaniServ DuraFreeze 200 saves valuable floor space and turns the countertop into a real profit center by serving high profit ice cream and yogurt products.

EASY CLEANING AND OPERATION

Fewer Parts = Simplified Cleaning – SaniServ equipment is designed and built with the fewer parts to be disassembled, cleaned and sanitized than any other machine in the industry.

HIGH RETURN ON INVESTMENT

Increased Profits – SaniServ machines combine affordable efficiency with consistent product quality and fast quiet operation to insure customer satisfaction with high profit frozen beverages.

QUALITY DESIGN

Durability – SaniServ machines are built to achieve long and dependable life through simplicity of design. Every machine is shipped standard with a stainless steel exterior, durable construction, heavy-duty components and consistency systems.

Model DF200

Countertop
Soft Serv
Ice Cream / Yogurt Machine
DuraFreeze



Made in USA

We reserve the right to change specifications and products design without notice. Such revisions do not entitle the buyer to corresponding changes, improvements, additions or replacements for previously purchased equipment

MODEL DF200

Countertop Soft Serv Ice Cream / Yogurt Machine

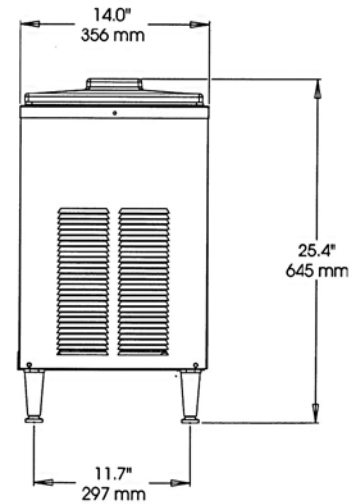
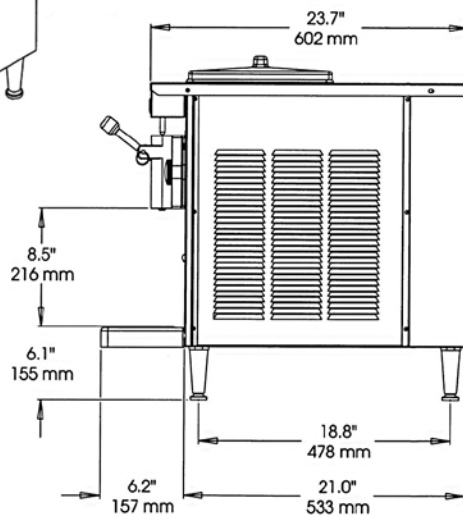
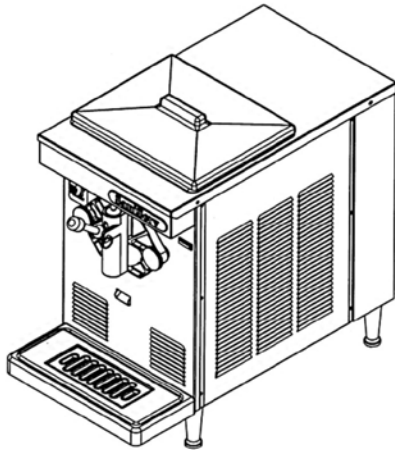

Minimum Wall Clearance
Both Sides and Back -
6 inches (152 mm)

ELECTRICAL				WIDTH	HEIGHT	DEPTH	WEIGHT	VOLUME
VOLTS	Hz	Ph.	Amps	INCHES (MM)	INCHES (MM)	INCHES (MM)	LBS. (Kg)	CU FT. (cu. m.)
115	60	1	15	14 (356)	25.4 (645)	23.7 (602)	145 (66)	
Shipping Specifications				22.5 (571)	31.5 (800)	34.5 (876)	172 (78)	8.6 (.25)

Specifications:

Cooling System:

Air Only

Dasher and Compressor Motor:

1/2 HP Dasher
1/2 HP Compressor

Refrigerant Type:

R404A

Listings:

UL, cUL, NSF

Features:

Evaporator and Mix Reservoir

Capacity:
7 Quarts (5.7 liters)

Dasher:

Heavy-Duty Stainless Steel with low friction scraper blades.

Controls:

Automatic consistency controls.

Warranty:

Parts 90 days
Compressor 1 year
Labor 30 days

Options:

Tune Up Kit
Machine Stand
Custom Graphic



DESIGNED FOR LOW VOLUME APPLICATIONS

Two Quart Capacity

ECONOMICAL IN PRICE & SPACE!

The **SaniServ DuraFreeze** DF300 two-quart batch freezer is ideal for providing small servings, samplers, and adding a-la-mode to favorite desserts. Producing a single yield of high profit, consistent quality product was never easier! Rapid disassembly and assembly makes this Batch Freezer easy to use and operate. Economical in price and space, *DuraFreeze* offers the prospect for high profits and customer satisfaction.

SPACE SAVING

Small Footprint Design - SaniServ DuraFreeze 300 saves valuable floor space and turns the countertop into a real profit center by serving high profit ice cream gelato, sorbet and sherbet products.

EASY CLEANING AND OPERATION

Fewer Parts = Simplified Cleaning – SaniServ equipment is designed and built with the fewer parts to be disassembled, cleaned and sanitized than any other machine in the industry.

HIGH RETURN ON INVESTMENT

Increased Profits – SaniServ machines combine affordable efficiency with consistent product quality and fast quiet operation to insure customer satisfaction with high profit frozen beverages.

QUALITY DESIGN

Durability – SaniServ machines are built to achieve long and dependable life through simplicity of design. Every machine is shipped standard with a stainless steel exterior, durable construction, heavy duty components and consistency systems.

Model DF300

Countertop
**Two Quart
Batch Freezer
DuraFreeze**



Shown with Optional Graphic



Made in USA

We reserve the right to change specifications and products design without notice. Such revisions do not entitle the buyer to corresponding changes, improvements, additions or replacements for previously purchased equipment

MODEL DF300

Countertop Batch Freezer

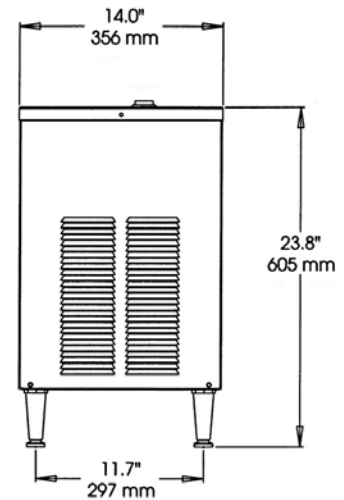
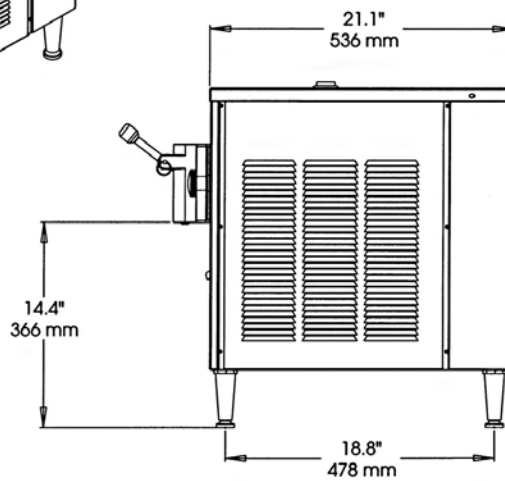
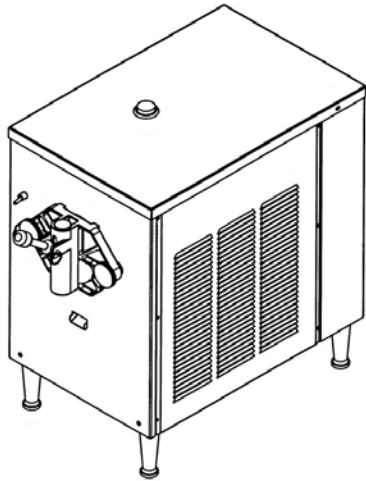

Minimum Wall Clearance
Both Sides and Back -
6 inches (152 mm)

ELECTRICAL				WIDTH	HEIGHT	DEPTH	WEIGHT	VOLUME
VOLTS	Hz	Ph.	Amps	INCHES (MM)	INCHES (MM)	INCHES (MM)	LBS. (Kg)	CU FT. (cu. m.)
115	60	1	15	14 (356)	23.8 (605)	21.1 (536)	145 (66)	
Shipping Specifications				18.5 (470)	25.5 (648)	31.5 (800)	172 (78)	8.6 (.24)

Specifications:

Cooling System:

Air Only

Dasher and Compressor Motor:

1/2 HP Dasher
1/2 HP Compressor

Refrigerant Type:

R404A

Listings:

UL, cUL, NSF

Features:

Evaporator and Mix Reservoir

Capacity:
2 Quarts (1.9 liters)

Dasher:

Heavy-Duty Stainless Steel with low friction scraper blades.

Controls:

Automatic shut of timer.

Warranty:

Parts 90 days
Compressor 1 year
Labor 30 days

Options:

Tune Up Kit
Machine Stand
Custom Graphic
Funnel



Designed To Meet the Needs of Restaurants, Caterers, Hotels, Clubs, Ice Cream Shops and Water Ice Companies

The **SaniServ** model B5 Batch Freezer produces a single yield of high profit, consistent quality product every time! Easy to operate, clean and sanitize. Rapid disassembly and assembly makes the Batch Freezer a favorite among owners and operators. The short production time provides a simple and easy way to provide a batch of single flavor of high quality product every time! With the versatility to add mix-in's after production the flavor choices are endless!

COUNTERTOP MODEL

Meets Your Requirements - SaniServ model B5 turns valuable space into a real profit center by producing a batch of high profit frozen product every time.

EASY CLEANING AND OPERATION

Fewer Parts = Simplified Cleaning – SaniServ equipment is designed and built with the fewer parts to be disassembled, cleaned and sanitized than any other machine in the industry.

HIGH RETURN ON INVESTMENT

Increased Profits – SaniServ machines combine efficiency with consistent product quality and fast quiet operation while insuring customer satisfaction with high profit ice cream or yogurt products.

QUALITY DESIGN

Durability – SaniServ machines are built to achieve long and dependable life through simplicity of design. Every machine is shipped standard with a stainless steel exterior, durable steel interior frame construction, heavy-duty components and consistency systems.

Model B5

Countertop
Batch Ice Cream Freezer



Made in USA

We reserve the right to change specifications and products design without notice. Such revisions do not entitle the buyer to corresponding changes, improvements, additions or replacements for previously purchased equipment

MODEL B5

Batch Freezer Series

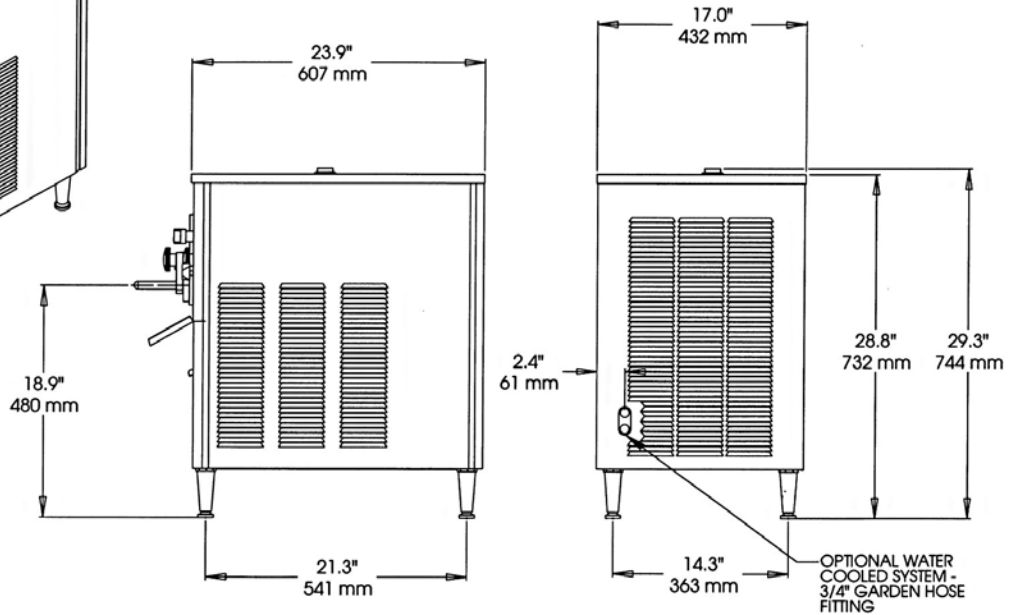
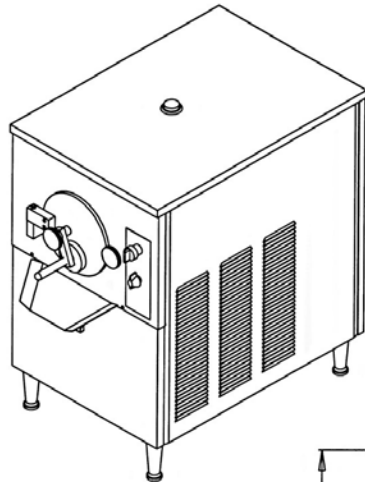

Minimum Wall Clearance
Both Sides and Back -
6 inches (152 mm)

ELECTRICAL				WIDTH	HEIGHT	DEPTH	WEIGHT	VOLUME
VOLTS	Hz	Ph.	Amps	INCHES (MM)	INCHES (MM)	INCHES (MM)	LBS. (Kg)	CU FT. (cu. m.)
208-230	60	1	20	17 (432)	29.3 (744)	23.9 (607)	220 (100)	
208-230	60	3	15					
Shipping Specifications				22.5 (571)	41 (1042)	34.5(876)	252 (114)	18.5 (.53)

Specifications:

Cooling System:
Air or Water

Dasher and Compressor Motor:

1 HP Dasher
1 HP Compressor

Refrigerant Type:

R404A

Listings:

UL, cUL, NSF

Features:

Batch Capacity:
5 qts. (4.7 liters)

Dasher:

Heavy-Duty Stainless Steel with low friction scraper blades.

Controls:

Automatic shut-off timer.

Warranty:

Parts 1 year
Compressor 5 years
Evaporator 5 years

Options:

Tune Up Kit
Syrup Rail
Counter Model Machine Stand
Water Cooled -3/4" (19.05 mm)
Garden Hose Fitting
Export Voltage



Designed To Meet the Needs of Restaurants, Caterers, Hotels, Clubs, Ice Cream Shops and Water Ice Companies

The **SaniServ** model B10 Batch Freezer produces a single yield of high profit, consistent quality product every time! Easy to operate, clean and sanitize. Rapid disassembly and assembly makes the Batch Freezer a favorite among owners and operators. The short production time provides a simple and easy way to provide a batch of single flavor of high quality product every time! With the versatility to add mix-in's after production the flavor choices are endless!

FLOOR MODEL

Meets Your Requirements - SaniServ model B10 turns valuable space into a real profit center by producing a batch of high profit frozen product every time.

EASY CLEANING AND OPERATION

Fewer Parts = Simplified Cleaning - SaniServ equipment is designed and built with the fewer parts to be disassembled, cleaned and sanitized than any other machine in the industry.

HIGH RETURN ON INVESTMENT

Increased Profits - SaniServ machines combine efficiency with consistent product quality and fast quiet operation while insuring customer satisfaction with high profit ice cream or yogurt products.

QUALITY DESIGN

Durability - SaniServ machines are built to achieve long and dependable life through simplicity of design. Every machine is shipped standard with a stainless steel exterior, durable steel interior frame construction, heavy-duty components and consistency systems.

Model B10

Floor Model
Batch Ice Cream Freezer



Made in USA

We reserve the right to change specifications and products design without notice. Such revisions do not entitle the buyer to corresponding changes, improvements, additions or replacements for previously purchased equipment

MODEL B10

Batch Freezer Series

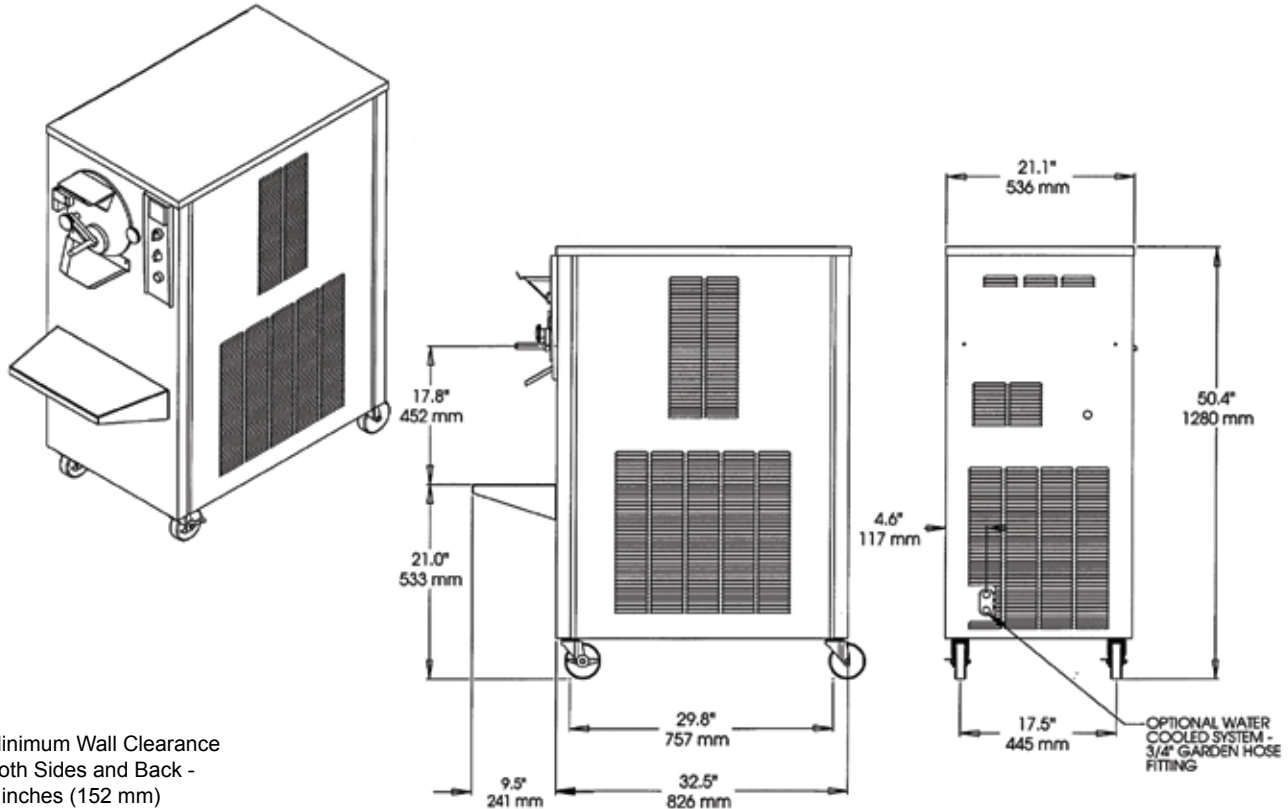

Minimum Wall Clearance
Both Sides and Back -
6 inches (152 mm)

ELECTRICAL				WIDTH	HEIGHT	DEPTH	WEIGHT	VOLUME
VOLTS	Hz	Ph.	Amps	INCHES (MM)	INCHES (MM)	INCHES (MM)	LBS. (Kg)	CU FT. (cu. m.)
208-230	60	1	35	21 (536)	50.4 (1280)	32.5 (826)	520 (236)	
208-230	60	3	20					
Shipping Specifications				35 (889)	54 (1371)	40 (1016)	547 (248)	43.8 (1.24)

Specifications:

Cooling System:
Air or Water

Dasher and Compressor Motor:
3 HP Dasher
2 HP Compressor

Refrigerant Type:
R404A

Listings:
UL, cUL, NSF

Features:

Batch Capacity:
10 qts. (9.5 liters)

Dasher:
Heavy-Duty Stainless Steel with low friction scraper blades.

Controls:
Automatic shut-off timer.

Warranty:

Parts 1 year
Compressor 5 years
Evaporator 5 years

Options:

Tune Up Kit
Syrup Rail
Water Cooled -3/4" (19.05 mm)
Garden Hose Fitting



Designed To Meet the Needs of Restaurants, Caterers, Hotels, Clubs, Ice Cream Shops and Water Ice Companies

The **SaniServ** model B20 Batch Freezer produces a single yield of high profit, consistent quality product every time! Easy to operate, clean and sanitize. Rapid disassembly and assembly makes the Batch Freezer a favorite among owners and operators. The short production time provides a simple and easy way to provide a batch of single flavor of high quality product every time! With the versatility to add mix-in's after production the flavor choices are endless!

FLOOR MODEL

Meets Your Requirements - SaniServ model B20 turns valuable space into a real profit center by producing a batch of high profit frozen product every time.

EASY CLEANING AND OPERATION

Fewer Parts = Simplified Cleaning – SaniServ equipment is designed and built with the fewer parts to be disassembled, cleaned and sanitized than any other machine in the industry.

HIGH RETURN ON INVESTMENT

Increased Profits – SaniServ machines combine efficiency with consistent product quality and fast quiet operation while insuring customer satisfaction with high profit ice cream or yogurt products.

QUALITY DESIGN

Durability – SaniServ machines are built to achieve long and dependable life through simplicity of design. Every machine is shipped standard with a stainless steel exterior, durable steel interior frame construction, heavy-duty components and consistency systems.

Model B20

Floor Model
Batch Ice Cream Freezer



We reserve the right to change specifications and products design without notice. Such revisions do not entitle the buyer to corresponding changes, improvements, additions or replacements for previously purchased equipment

MODEL B20

Batch Freezer Series

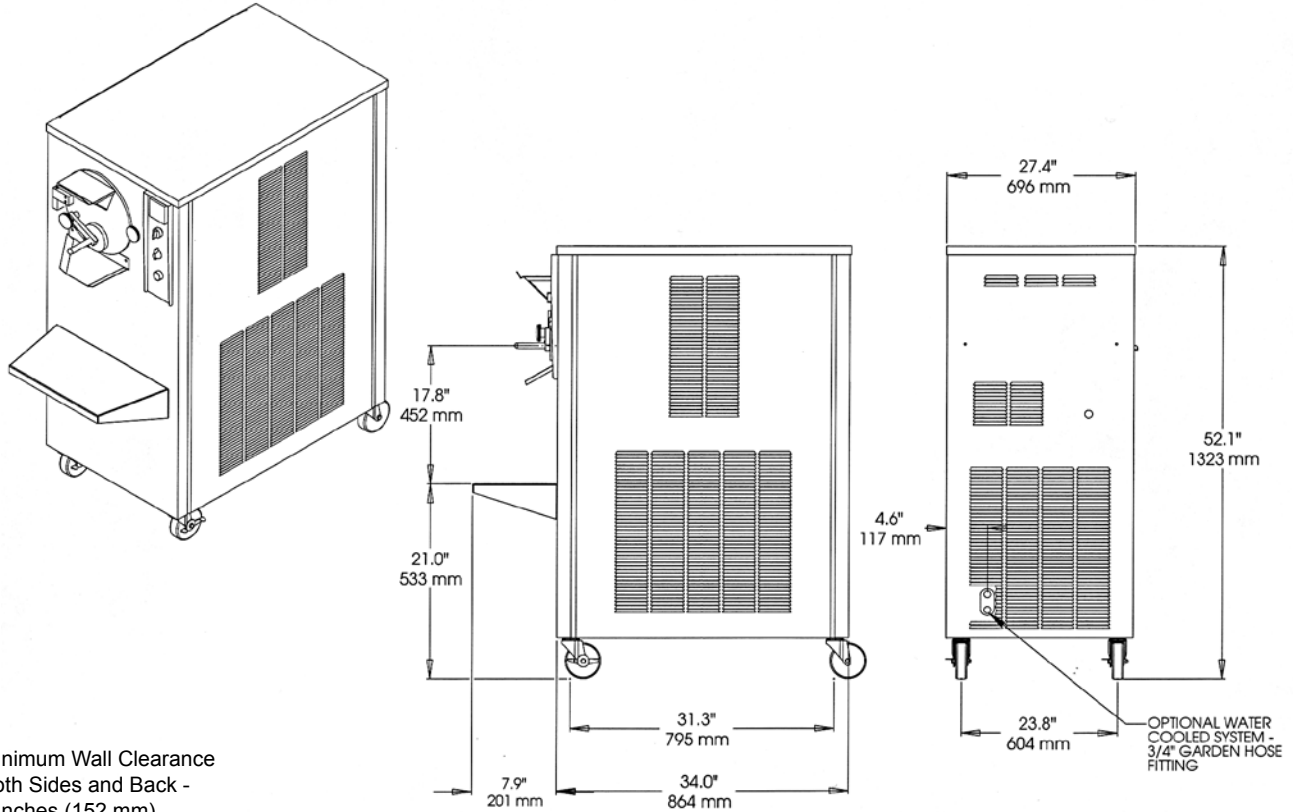

Minimum Wall Clearance
Both Sides and Back -
6 inches (152 mm)

ELECTRICAL				WIDTH	HEIGHT	DEPTH	WEIGHT	VOLUME
VOLTS	Hz	Ph.	Amps	INCHES (MM)	INCHES (MM)	INCHES (MM)	LBS. (Kg)	CU FT. (cu. m.)
208-230	60	3	40	27.4 (695)	52.1 (1324)	34.0 (864)	860 (391)	
Shipping Specifications				35 (889)	54 (1371)	40 (1016)	970 (438)	43.8 (1.24)

Specifications:

Cooling System:
Air or Water

Dasher and Compressor Motor:

3 HP Dasher
3 HP Compressor

Refrigerant Type:

R404A

Listings:

UL, cUL, NSF

Features:

Batch Capacity:
20 qts. (19 liters)

Dasher:

Heavy-Duty Stainless Steel with low friction scraper blades.

Controls:

Automatic shut-off timer.

Warranty:

Parts 1 year
Compressor 5 years
Evaporator 5 years

Options:

Tune Up Kit
Syrup Rail
Water Cooled -3/4" (19.05 mm)
Garden Hose Fitting



High Speed Compact Mixer for adding Flavorings To Soft Serv Ice Cream and Shakes

Add the **SaniServ** CYCLONE™ to your counter for blending special treats into Soft Serv Ice Cream and Shakes. Maximize Your Profits by adding popular high profit mix-ins, shakes and malts to your dessert offerings. You can offer products like milk shakes, malts, also many flavors and varieties of addins to Soft Serv ice cream with the addition of a CYCLONE™ mixer. High-speed mixing and spindle design insure even mixing from top to bottom of shakes, malts and flurrries. An Optional Foot Pedal is available for hands free operation of on/off switch.

SPACE SAVING

Small Footprint Design - It takes less than one square foot of counter space.

EASY CLEANING AND OPERATION

Fast and Easy Cleaning – **SaniServ** equipment is designed to be easily cleaned and sanitized, with the fewest parts possible for rapid assembly and disassembly.

HIGH RETURN ON INVESTMENT

Increased Profits – **SaniServ** machines combine efficiency with consistent product quality and fast quiet operation while insuring customer satisfaction with high profit ice cream or yogurt products.

QUALITY DESIGN

Durability – **SaniServ** machines are built to achieve long and dependable life through simplicity of design.

CYCLONE™

Countertop Model
Flurry/Shake Mixer



We reserve the right to change specifications and products design without notice. Such revisions do not entitle the buyer to corresponding changes, improvements, additions or replacements for previously purchased equipment

CYCLONE™

Counter Model Flurry/Shake Mixer

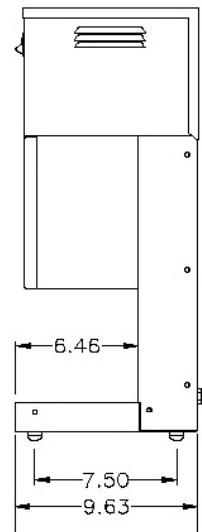
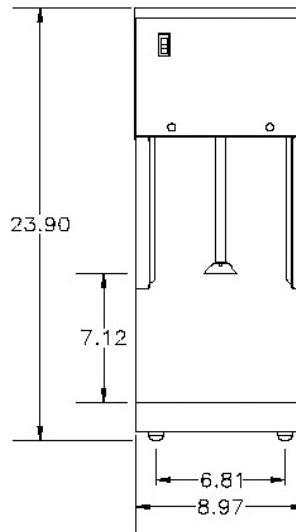
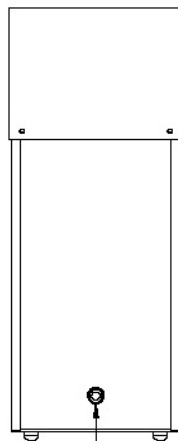
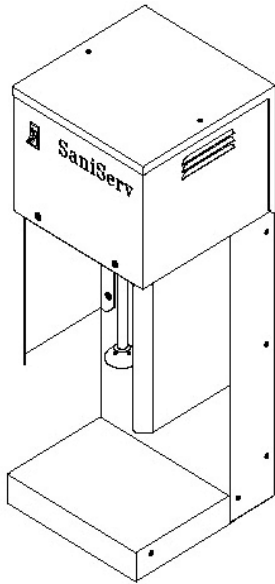

Minimum Wall Clearance
Both Sides and Back -
6 inches (152 mm)

STRAIN RELIEF FOR
POWER CORD -
CORD NOT SHOWN

ELECTRICAL				WIDTH	HEIGHT	DEPTH	WEIGHT	VOLUME
VOLTS	Hz	Ph.	Amps	INCHES (MM)	INCHES (MM)	INCHES (MM)	LBS. (Kg)	CU FT. (cu. m.)
115	60	1	15	9 (229)	24 (610)	9.6 (244)	33 (15)	
Shipping Specifications				11.75 (299)	25.25 (642)	13.75 (350)	35 (15.9)	2.4 (.07)

Specifications:

Motor:

High speed 3250 rpm 1/4 HP

Listings:

UL, cUL, NSF

Features:

Construction:

Corrosion resistant materials inside with all Stainless Steel exterior panels, mixer blade and mixer shaft

Controls:

Rocker type switch

Warranty:

Parts 1 year
Labor 90 days

Options:

Foot Pedal
Front Splash Shield
Wall Mount Bracket



Designed For High Volume Applications Great for use with any Frozen Beverage Machine

The **SaniServ** SAFS 12 or SAFS 24 is a Complete Integrated Auto Fill System for use with Pre-Mixed products, in any Frozen beverage application.

EASY PRODUCT HANDLING

One or Two Vat Systems - save valuable floor space with the compact design SaniServ's exclusive Mix Vat cart allows for transportation either one or two 12-gallon mix vats to be transported. The heavy duty cart comes with heavy duty casters, two which are locking, push handle, and mix vat locking plate. Auto Fill system and the box rack mounted inside an enclosed cart, which comes with 4 heavy-duty casters, 2 which are locking.

AUTO FILL PUMP SYSTEM

Complete Electric Pump System – with recirculating timer are installed on a stainless steel platform, which sits on the lid of the mix vat. Simply plug into a 115 V. outlet and it's ready to go. The S.S. Pump Platform fits in to a slot on the handle for easy storage when filling, cleaning or transporting mix vats.

EASY OPERATION

Recirculating Timer – Set timer to turn pump every hour for up to two 15-minute intervals to insure product is completely mixed.

Easy Cleaning and Filling – Simply roll the Mix Vat Cart to the sink area to wash, sanitize and refill vats. No heavy lifting of mix containers to refill machine.

MAXIMIZE YOUR PROFITS

Consistent Product Quality – Combine efficiency, product quality, cost control, ease in use and simplicity of operation. Always have product available during peak hours of operation.

COMPACT DESIGN

The small footprint easily fits into any operation using a minimum of cooler space.

Models SAFS12 SAFS24 Auto Fill System for Pre-Mixed Applications



Made in USA

We reserve the right to change specifications and products design without notice. Such revisions do not entitle the buyer to corresponding changes, improvements, additions or replacements for previously purchased equipment

MODEL SAFS12 or SAFS24

Auto Fill System for Pre-Mix Applications

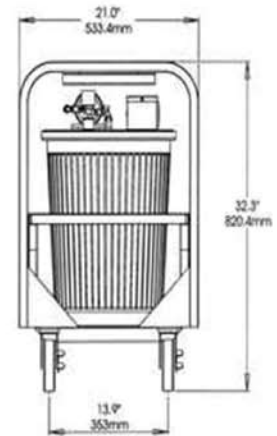
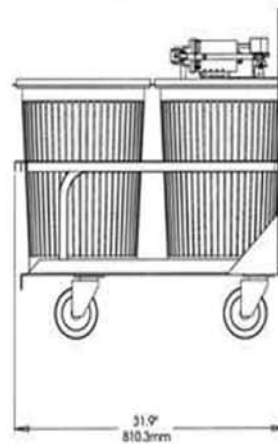
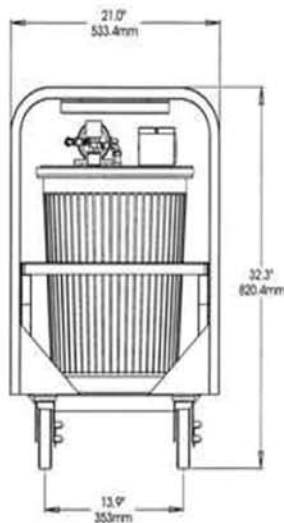
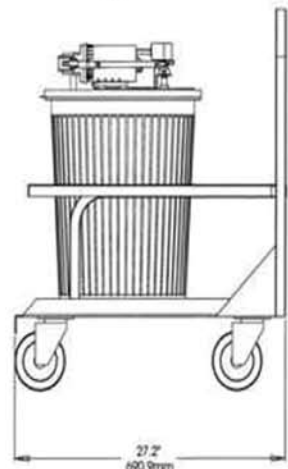
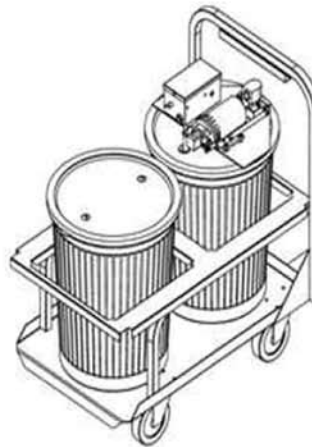
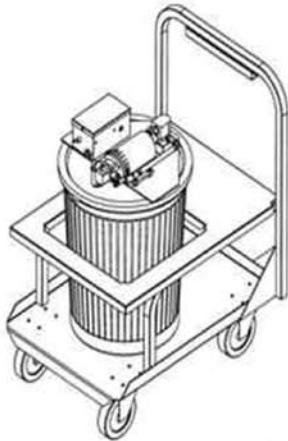

Minimum Wall Clearance
Both Sides and Back -
6 inches (152 mm)

SAFS12

SAFS24

ELECTRICAL				WIDTH	HEIGHT	DEPTH	WEIGHT	VOLUME
VOLTS	Hz	Ph.	Amps	INCHES (MM)	INCHES (MM)	INCHES (MM)	LBS. (Kg)	CU FT. (cu. m.)
115	60	1	15	21 (534)	32.3 (821)	27.2 (691) or 32 (813)	75 (34)	
Shipping Specifications				24 (610)	36.5 (927)	30 (762) or 36 (914)	85 (39)	15.3 (.43)

Specifications:

Mix Pump:

115 V. 60 1 phase

Timer:

24 Hour, recirculates 2 times per hour

Mix Vat Capacity:

12 Gallons

Beverage Line:

3/8 ID

Features:

Complete Pump Assembly mounted on stainless steel plate.

Heavy Duty Mix Vat Cart With Pump Storage Slot

Recirculating Timer

USDA Approved Plastic Mix Vats

12 or 24 Gallon Capacity

Warranty:

Parts 1 year

Options:

- Auto Fill Lid
- Extra Pump Platen Assembly (2 Flavors)
- Extra Mix Vats
- Extra Mix Vat Lids
- Beverage Line 3/8" in 25', 50, 75' lengths



MS Series Heavy-Duty Machine Stands Customized for your SaniServ Equipment

Free up valuable counter space and provide superior support for your equipment!

- Heavy-Duty - All stainless steel construction
- Available for all countertop models
- Optional casters
- Standard 30" height (see dimension chart)
- Custom configurations available
- Top surface embossed to match machine leg placement.
- "DI" models available with built-in drip tray, one ladle dispenser and one pump dispenser.



We reserve the right to change specifications and products design without notice. Such revisions do not entitle the buyer to corresponding changes, improvements, additions or replacements for previously purchased equipment

Machine Stands



MS163020SXDI
Includes built-in drip tray and syrup dispensers.

Model	Height	Depth *	Width	For SaniServ Model:
MS163018SX	30"	30"	18"	407, 707
MS163020SX	30"	30"	20"	401, 404, 408, 601, 608, 708, 709
MS163220SX	30"	32"	20"	B5
MS163222SX	30"	32"	22"	108
MS163620SX	30"	36"	20"	601SAS
MS163622SX	30"	36"	22"	704
MS163624SX	30"	36"	24"	798, 808
MS163626SX	30"	36"	26"	501

* DI Models: Add 6" to Depth

Designed For High Volume Applications Reduces Noise and Work Area Heat Build-up

The **SaniServ** Model ROC2361 (by Copeland®) Remote Condensing Unit, can be used with any SaniServ remote ready dispensing unit.

ROC2361

Remote Condensing Unit

Unit includes:

- Outdoor rated, 2 H.P. condenser
- Galvanized all-weather enclosure
- Contactor mounted and wired
- High and low pressure controls mounted and wired separately
- Immersion type crankcase heater

Optional:

- 25', 50' and 75' pre-charged lines available

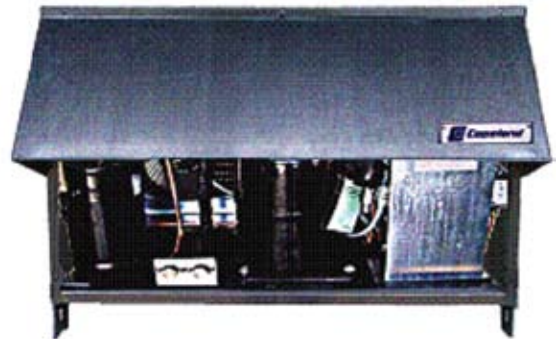

We reserve the right to change specifications and products design without notice. Such revisions do not entitle the buyer to corresponding changes, improvements, additions or replacements for previously purchased equipment

Specifications

Mechanical

Unit Height (in):	18.9
Unit Length(in):	25.1
Unit Width (in):	31.4
Ship Weight (lbs):	202.0
Condenser Type:	Air
Copevap Water Storage:	NA
Receiver Capacity (lbs):	10.3
Liquid Connection Size (in)/Type:	3/8 S
Suction Connection Size (in)/Type:	7/8 S
Discharge Line Size (in):	3/8
Water Inlet ("):	
Water Outlet ("):	
Oil Type:	POE
Oil Recharge Amount (oz):	45

Electrical

Max Fuse Size:	25
Min Circuit Ampacity:	17.8
Compressor:	CS14K6E-PFV-273
Compressor LRA - Low:	
Compressor LRA - High:	61.0
Compressor LRA - Half Winding:	
Compressor RLA:	12.4
UL:	Listed
UL File #:	SA633
UL Guide Card:	LZFE
CSA:	Certified
CSA File #:	LR58386
Amps Per Motor:	0.85
Fan Motor Quantity:	2

Air - Cooled Unit Performance

Release Date:	06-Jun-2002	Return Gas Temp. (°F):	40
Compressor:	CS14K6E-PFV-273 x 1	Subcooling (°F):	5
Performance No:	3755	Air Flow Rate (CFM):	1680
90°F Ambient Air Temperature			
Evap. Temp.	Unit Capacity	Cond. Temp.	Temp. Diff.
(°F)	(Btu/hr)	(°F)	(°F)
-5	9,030	105.5	15.5
0	10,400	107.4	17.4
5	11,900	108.8	18.8
10	13,400	110.6	20.6
15	14,900	112.4	22.4
20	16,400	114.1	24.1
25	17,900	115.9	25.9



Bucket Hanger Kit

The heavy duty **SaniServ** Bucket hanger is designed to eliminate the need for an employee to stand and hold a 25 to 30 pound bucket under the spigot while draining product, cleaning solutions or sanitizer during the cleaning process. Typically, rather than holding the bucket, the employee will rest it on the drip tray where the bucket can slip and spill. If the bucket has a bail they will hang it on the spigot plunger or handle. Hanging the bucket on the spigot eventually leads to the face plate cracking. It is not a case of *if* it will crack, but *when* it will crack. We have received many complaints from end users about cracking face plates. When we receive the face plate for inspection, 99% of the cracks are stress cracks caused by buckets hanging from the spigot. This is a very expensive part to replace.

The new Bucket Hanger fits on the top of the machine with one end extending into the mix pan and then hangs over the front of the machine. The hook on the front of the bucket hanger holds the bail of the bucket allowing the bucket to swing under the spigot opening. This makes the process nearly hands free.

The Bucket Hanger is made of 11 gage Stainless Steel and will support up to 20 quarts of liquid. The bucket hangers are machine specific, therefore, you will need to specify the model number when ordering the bucket hanger. Bucket Hangers are sold separately and in a kit which includes a specially designed heavy duty **SaniServ** bucket.

Buy Cleaning Buckets and rerun containers to increase your productivity with your **SaniServ** Products!

SaniServ, Almost Plug and Play!

Bucket Hanger



Made in USA

We reserve the right to change specifications and products design without notice. Such revisions do not entitle the buyer to corresponding changes, improvements, additions or replacements for previously purchased equipment

MODEL NUMBER.	MODEL DESCRIPTION	HANGER NUMBER	WHITE BUCKET	GREY BUCKET	RED BUCKET
798	SLUSH MACHINE	110162	SLB12140	SLB12181	SLB12158
707	SLUSH MACHINE	110163	SLB12140	SLB12181	SLB12158
501, 527	TWIST MACHINE	110164	SLB12140	SLB12181	SLB12158
522, 521	TWIST MACHINE	110165	SLB12140	SLB12181	SLB12158
407	ICE CREAM	110166	SLB12140	SLB12181	SLB12158
ALL OTHER 400 SERIES	ICE CREAM	109928	SLB12140	SLB12181	SLB12158
ALL OTHER 600 SERIES	MILK SHAKE	109928	SLB12140	SLB12181	SLB12158
ALL OTHER 700 SERIES	SLUSH MACHINE	109928	SLB12140	SLB12181	SLB12158

Insulated Lid For Ice Cream and Shake Machines

The new **SaniServ Insulated** lid for ice cream and shake machines, has been designed to improve the overall performance for any **SaniServ** machine. The new insulated lid is a must for the safety conscious restaurateur offering the following advantages:

- Reduced the overall temperature range of the mix being held in the mix reservoir by up to 4 degrees. This is essential to the successful placement of a Burger King unit.
- Prolongs the shelf life of the mix due to lower reservoir temperature.
- Reduces bacteria counts in the mix in the reservoir. Mix can be held longer with less waste.
- Improves production and recovery time of the machine due to the lower temperature of the mix.
- Improved service life of the lid because of the stronger construction and double wall thickness at edges.
- Save energy due to shorter recovery cycle time.
- Fits all 15 Quart mix reservoirs.

Buy the new insulated lid for your existing SaniServ machine to improve energy efficiency and performance!

Insulated Lid Ice Cream and Shake Machines



Made in USA

We reserve the right to change specifications and products design without notice. Such revisions do not entitle the buyer to corresponding changes, improvements, additions or replacements for previously purchased equipment



Storage Containers

SaniServ storage containers are available in N.S.F. and U.S.D.A approved food grade translucent plastic material complete with graduations. They are also available in natural white plastic material. These containers are ideal for your customers to store liquids, food products, dry ingredients or any number of other uses.

Designed for use at temperatures between 10 and 180 degrees the translucent containers with graduations are ideal for mixing and storing, soft serve, shake and frozen beverage mixes requiring refrigeration. The graduations make it easy to measure ingredients or to quickly see the type and quantity of product in the container.

Our molded in reverse curved handles make lifting even heavy load comfortable. The containers come in a variety of sizes from two quarts to forty quarts in capacity. The twenty-four quart is ideal for mixing five-gallon batches.

The natural white storage containers are more flexible, making them very durable and more resistant to temperature fluctuations. These containers are designed for use from -40 to 140 degrees fahrenheit. They are available in the same sizes as the translucent containers.

Lids are available in natural white, red, green, blue and yellow in all sizes.

Also available is a 15 Quart utility pail ideal for cleaning and sanitizing machines. They are available in gray, white, and red. They are also graduated on the inside for easy filling.

The 12 gallon plastic container and lid that is used with the auto fill system is available in natural white. Special colors may be ordered with quantities and lead times.

Totes and food storage boxes are available in 5" and 7" depths. These boxes are heavy duty and are available in translucent, natural white, black, gray, brown, red, green and yellow. Lids are also available.

Buy a package of products that make it easy to use your **SaniServ** Machine!

Storage Containers



Made in USA

We reserve the right to change specifications and products design without notice. Such revisions do not entitle the buyer to corresponding changes, improvements, additions or replacements for previously purchased equipment

Cord Sets

SaniServ is pleased to announce the availability of the cord, plug and receptacle options for all 230 volt machines. The cord and plug will be assembled but not attached to the machine and shipped with receptacle. This is part of our “Plug and Play” concept. Making ownership of **SaniServ** equipment as friendly as possible is top priority.

We have received many inquiries as to why we don't provide the cord and plug on all of our machines. The problem lies with UL, which doesn't allow for the cord and plug to be attached to the machine.

Many customers don't realize that the machine will not have a cord and plug, then have to pay the electrician to go and source a cord and plug. This is an extra expense for them. By the same token, if we ship just the cord and plug, it is unlikely that the customer has the proper receptacle and the same process occurs.

Increase your customer's satisfaction, simplify the “Plug and Play” installation process by specifying and adding the cord, plug and receptacle option to all of your quotes.

Use this value added option to increase your sales!

Cord Sets



20 Amp 1 Ph. cord shown Receptacle not shown



Made in USA

We reserve the right to change specifications and products design without notice. Such revisions do not entitle the buyer to corresponding changes, improvements, additions or replacements for previously purchased equipment



Accessories

AF-1 AUTO FILL KIT

- Automatically maintains mix level in reservoir from remote location
- Bag in the Box or remote bulk tank
- Optional remote transfer pump
- 115 Volt cord and plug attached Recommended for frozen beverage only



LIGHT BOX

- Increase merchandising
- Front or Top mount
- Available for most units



PARTS TRAY

- Keep track of all parts during cleaning
- Provides for air drying and storage of parts as suggested by many local Health Departments
- Available for most machines



WASH OUT KIT

- Hot & Cold Water Hook-Up to speed rinsing and cleaning of machine
- Available on most models
- Labor saving option



Made in USA

Accessories



SPINNER/MIXER

- Blends shakes & frozen beverage flavors
- Available on most shake & frozen beverage machines
- Front or Side Mount 115/60 or 220/60 available



SYRUP RAILS & DISPENSERS

- Expand flavor choices
- Hot wells available
- Available on floor & counter models
- Portion pumps available
- Also available built into stand

Side Mounts Syrup Rail for Shake Flavorings



Front Mount Flavor Dispenser for Frozen Beverages



Front Mount Syrup Rail for Soft Serv Toppings



Made in USA

Almost Plug and Play

The *AccuFreeze* Advantage

1. **AccuFreeze** controls have no moving parts to wear out, break or maintain. This state-of-the-art electronic design is preset at the factory for optimum product control.
2. **AccuFreeze** utilizes viscosity not temperature to control the quality of the product being served. This process creates the smoothest most consistent frozen treats available today.
3. **AccuFreeze** provides personalized product preference settings by incorporating one simple adjustment for consistency control. No more grooved pulleys, springs or idlers that squeak and need adjusting. This provides trouble free operation for the machine owner.
4. **AccuFreeze** uses a specially designed “V” belt that wears in not out. This feature provides the quietest operating machine available in the industry.
5. **AccuFreeze** controllers incorporate a self diagnostic feature that provides the servicer with vital information in the unlikely event of a service call. This shortens trouble shooting time for the servicer lowering service costs for the owner.
6. **AccuFreeze** incorporates a three minute lockout timer to prevent machine damage due to operator error. **AccuFreeze** protects the owner’s investment by preventing freeze ups due to low mix in the reservoir.
7. **AccuFreeze** controls provide for worry free operation that provides the best quality product in the industry. It is so easy that any one can do it. We like to call our new **AccuFreeze** controlled units plug and play. Just plug them in and they do the rest.



SaniServ

Serving you yesterday, today and tomorrow.

www.saniserv.com